

FUEL SYSTEM

CONTENTS

<i>FUEL TANK / FUEL COCK</i>	4- 1
<i>FUEL PUMP</i>	4- 2
<i>CARBURETOR</i>	4- 3

⚠ CAUTION

Gasoline must be handled carefully in an area well ventilated and away from fire or sparks.

FUEL TANK / FUEL COCK

⊙ REMOVAL

⚠ WARNING

Gasoline is very explosive. Extreme care must be taken.

- Remove the front seat. (Refer to page 6-1)
- Remove the fuel tank mounting nut and bolt, and take off the hooks.

- Turn the fuel cock to “OFF” and disconnect the fuel hose ①.
- Remove the fuel tank.

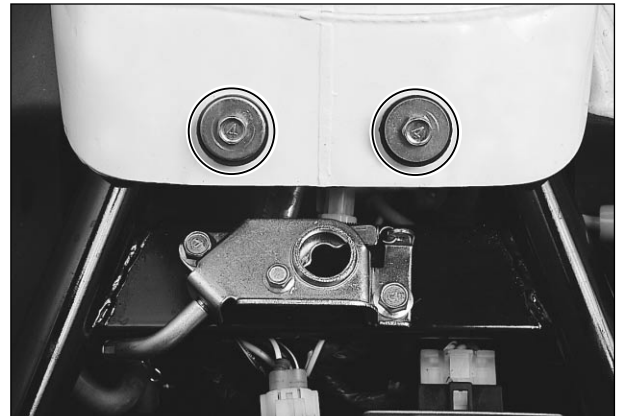

- Remove the fuel cock.



⊙ INSPECTION

■ FUEL COCK

If the fuel filter is dirty with sediment or rust, fuel will not flow smoothly and loss in engine power may result. Clean the fuel filter with compressed air. Also check the fuel cock for cracks.

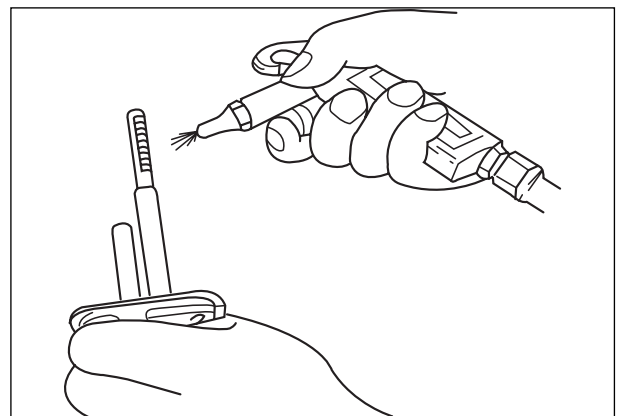

⊙ REMOUNTING

Remount the fuel tank and fuel cock in the reverse order of removal.

⚠ WARNING

- ❖ Gaskets ① and ② must be replaced with new ones to prevent fuel leakage.
- ❖ Tighten the fuel cock bolts evenly.

FUEL PUMP

⊙ REMOVAL

- Remove the left frame cover. (Refer to page 6-3)
- Turn the fuel cock to "OFF".
- Disconnect the fuel hoses ③, ④.
- Remove the fuel pump mounting bolts.
- Remove the fuel pump lead wire coupler ⑤.

⊙ INSPECTION

⚠ WARNING

Gasolin is very explosive. Extreme care must be taken.

- Disconnect the fuel hose ③, connect the suitable hose and insert the free end of the hose into a receptacle.

Check the fuel flow when starting the engine for few seconds by pressing the starter switch.

If the fuel flow is not found, check the fuel cock. (Refer to page 4-1)

If the fuel cock and hoses are not fault, check the fuel pump. (Refer to page 5-21)

⊙ REASSEMBLY

Carry out the assembly procedure in the reverse order of disassembly.

- Connect the fuel pump lead wire coupler ⑤.
- Tighten the fuel pump mounting bolts.
- Connect the fuel hoses ③, ④ securely.

FUEL HOSE ROUTING :

Fuel hose ③ (To fuel cock)

Fuel hose ④ (To carburetor)

⊙ FUEL PUMP RELAY

- Remove the fuel pump relay mounting bolts and coupler.
- Disconnect the fuel hose ④, and check the fuel flow when starting the engine for few seconds by pressing the starter switch.
- If the fuel pump are not fault, check the fuel pump relay. (Refer to page 5-21)

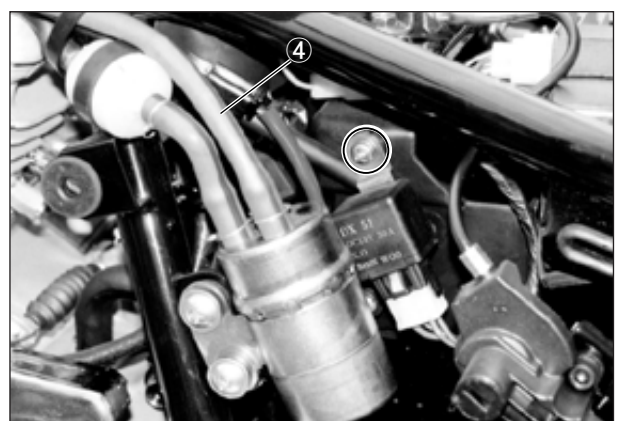
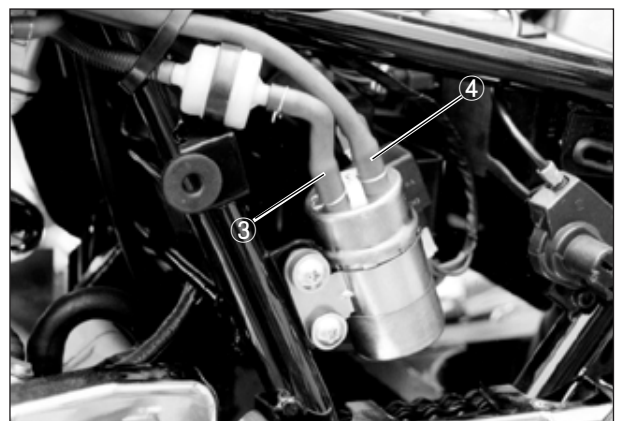
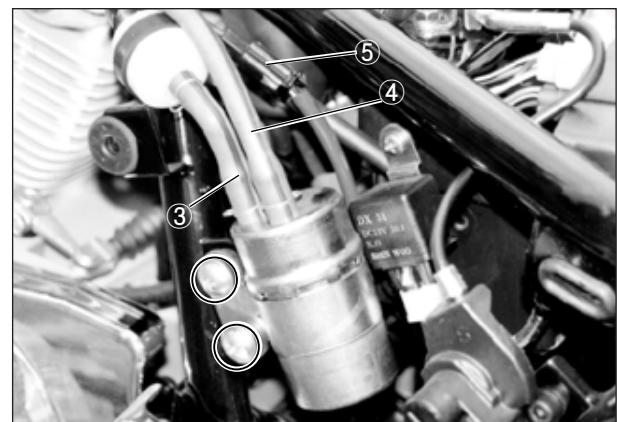
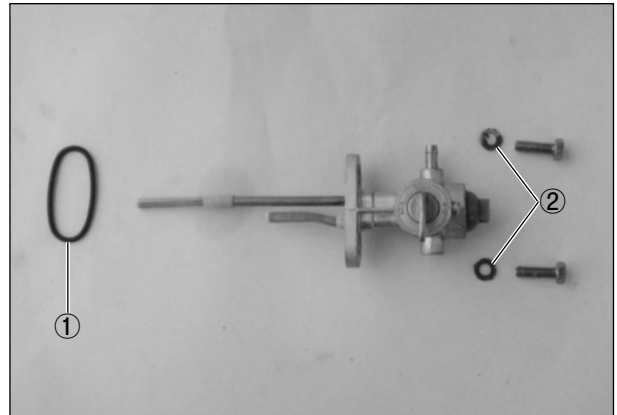

CARBURETOR

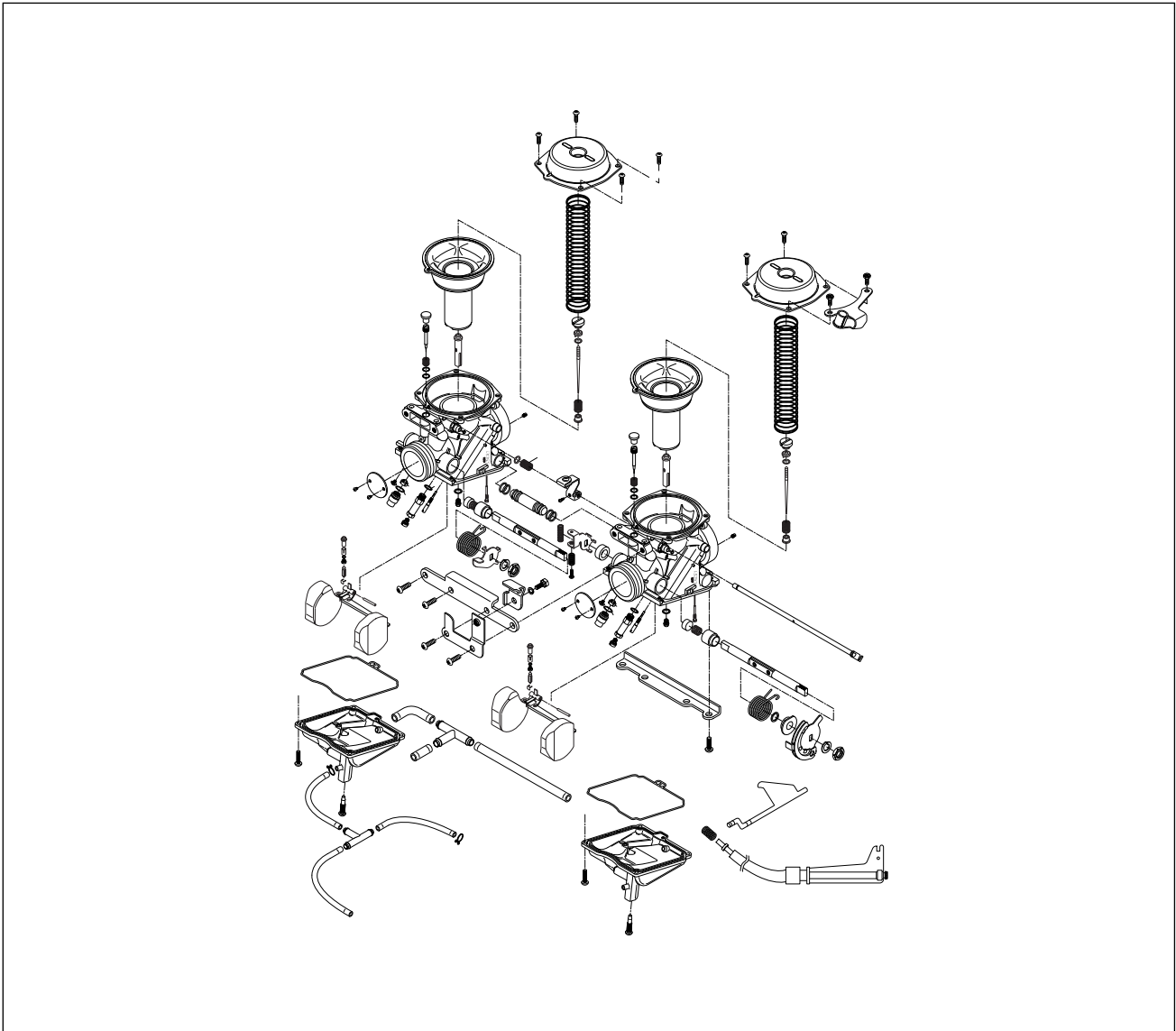

ITEM	SPECIFICATION		ITEM	SPECIFICATION	
Carburetor type	MIKUNI BDS 26 TYPE (DOUBLE)		Needle jet (N.J.)	O-6	O-6
Bore size	φ 26		Pilot jet (P.J.)	20	20
I.D. NO.	HJ82		Throttle valve (TH.V.)	130	130
Idle rpm	1,450 ~ 1,550 rpm		By pass (B.P.)	# 1:0.9, # 2:0.9, # 3:0.8, # 4:0.8	# 1:0.9, # 2:0.9, # 3:0.8, # 4:0.8
Float height	17		Valve seat (V.S.)	1.2	1.2
Throttle cable play	0.5~1.0		Starter jet (G.S.)	22.5	22.5
	FRONT	REAR	Pilot outlet (P.O.)	0.75	0.75
Main jet (M.J.)	90	87.5	PV STROKE (P.V.)	STD	STD
Main air jet (M.A.J.)	140	140			
Jet needle (J.N.)	2ND	2ND			

⦿ **LOCATION OF CARBURETOR I.D. NO.**

The carburetor I.D. is stamped on the location ① on the carburetor as shown in the right photo.

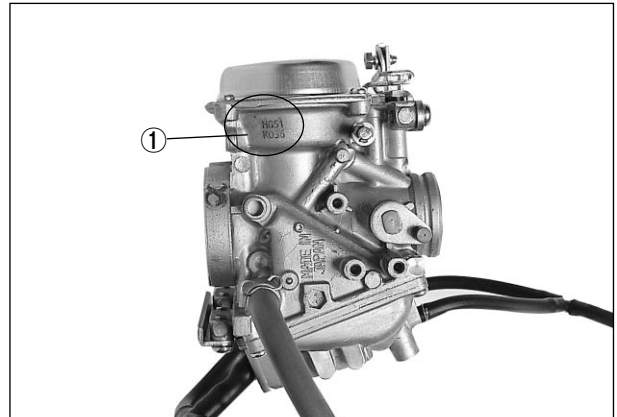

⦿ **REMOVAL**

- Remove the fuel tank. (Refer to page 4-1)
- Remove the fuel hose.

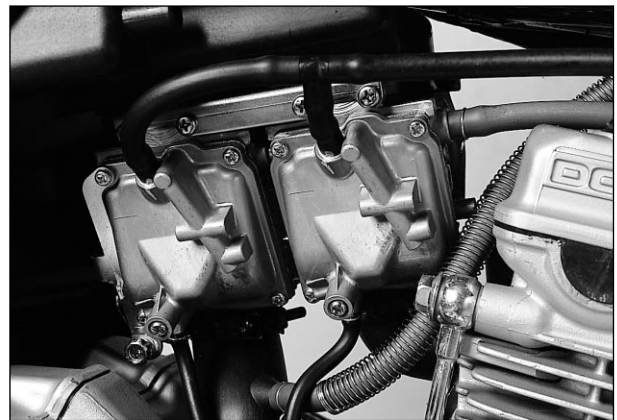

- Remove the throttle cables ② and choke cable ③.
- Loosen the clamp screw and remove the carburetor.



⦿ **DISASSEMBLY**

- Remove the diaphragm cover ④.



4-5 FUEL SYSTEM

- Remove the spring ① and piston valve ② along with diaphragm ③.

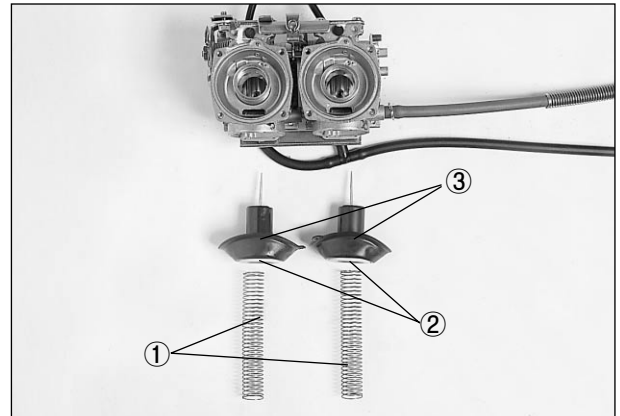

- Remove the jet needle cap ④, spring ⑤, retainer ⑥, and jet needle ⑦.

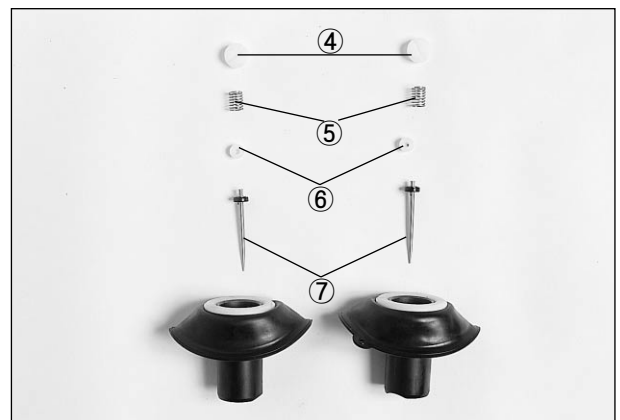

- Remove the float chamber body ⑧.

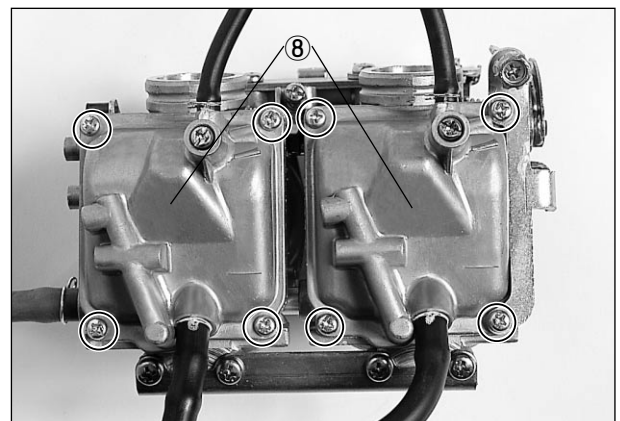

- Remove the float assembly ⑩ along with the needle valve ⑨ by removing the pin.

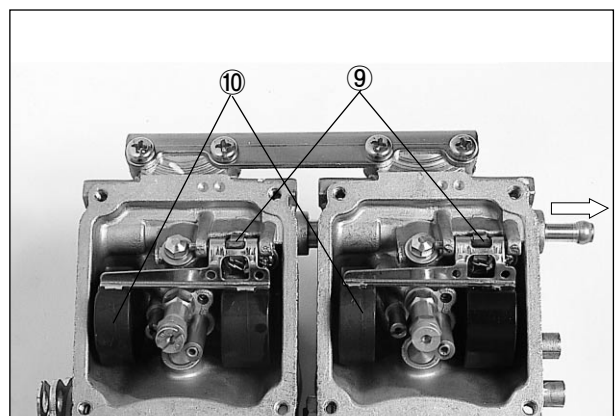

- Remove the valve seat ①.
- Remove the main jet ②, jet holder ③ and pilot jet ④.

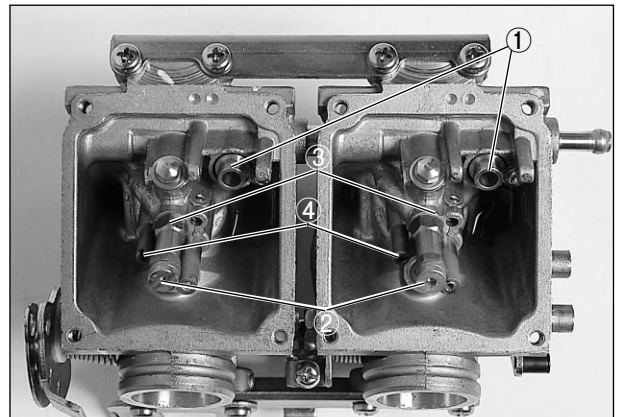

- Remove the throttle cable bracket ⑤.



- Remove the pilot screw ⑥ with count and tighten the number of turn.

NOTE:

Record the number of turn for the pilot screw when install to confer.

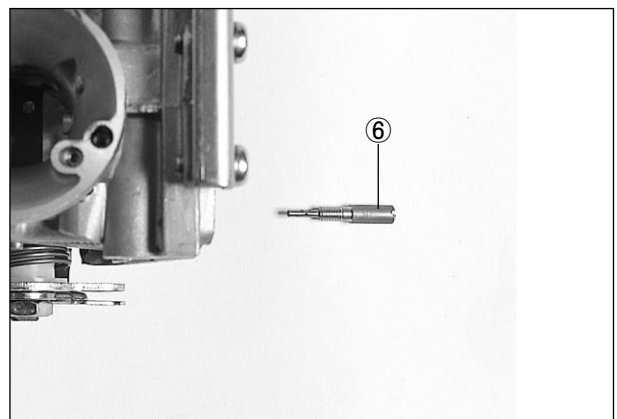

⊙ **INSPECTION**

Check the following parts for damage and clogging.

- | | |
|---------------------|---------------------------|
| · Pilot jet | · Piston valve |
| · Main jet | · Starter jet |
| · Main air jet | · Gaskets and O-rings |
| · Pilot air jet | · Pilot outlet and bypass |
| · Needle jet holder | · Float |
| · Needle valve | · Jet needle |
| · Valve seat | |

If any abnormal condition is found, wash the part clean.
If damage or clogging is found, replace the part with a new one.

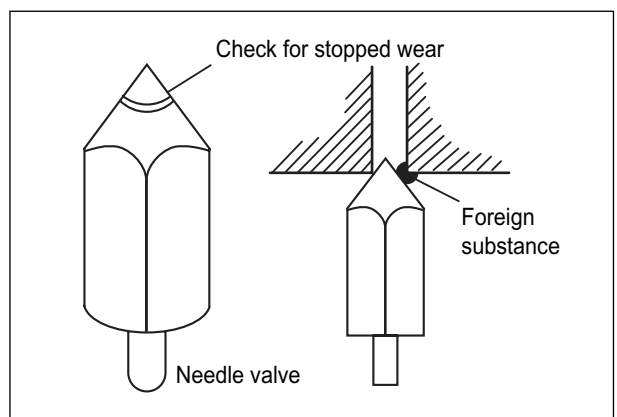

4-7 FUEL SYSTEM

⊙ CLEANING

- Clean all jets by using compressed air.
- After cleaning, reassemble the carburetor with new seals and gaskets.

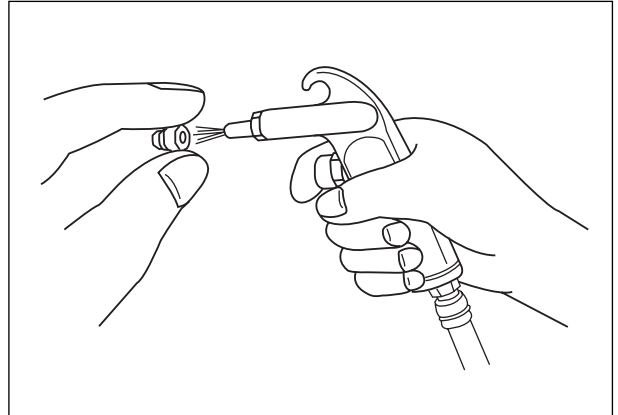

⊙ FLOAT HEIGHT ADJUSTMENT

To check the float height, turn the carburetor upside down. Measure the float height A while the float arm is just contacting the needle valve using vernier calipers.

Float height A

17mm

 Vernier calipers : 09900-20101

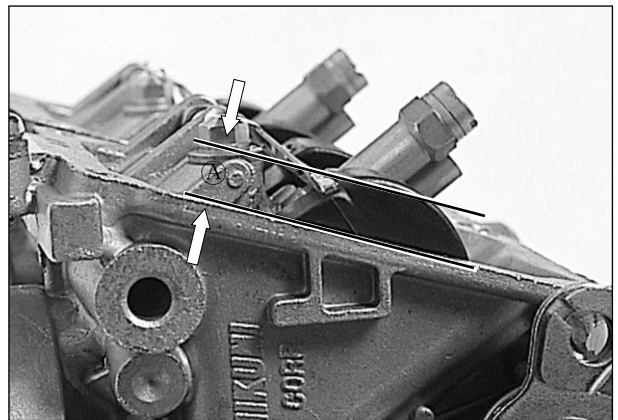

- Bend the float arm ① as necessary to bring the height A to the specified level.
- After adjustment, check the float height and the fuel level again.

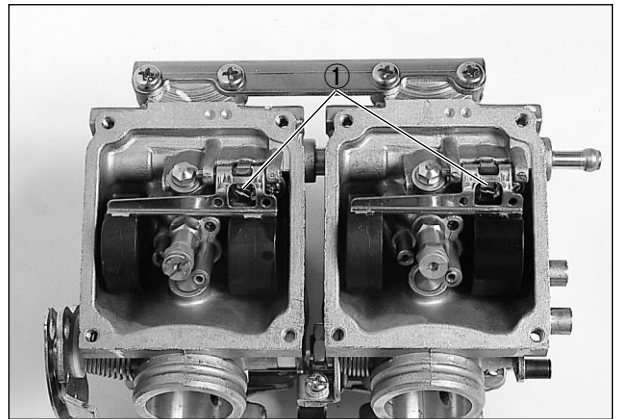

⊙ REASSEMBLY

Carburetor reassembly can be performed in the reverse order of disassembly. When reassembling, carefully observe the following instructions.

- After cleaning, reinstall the pilot screw to the original number of turn that is recorded during disassembly.

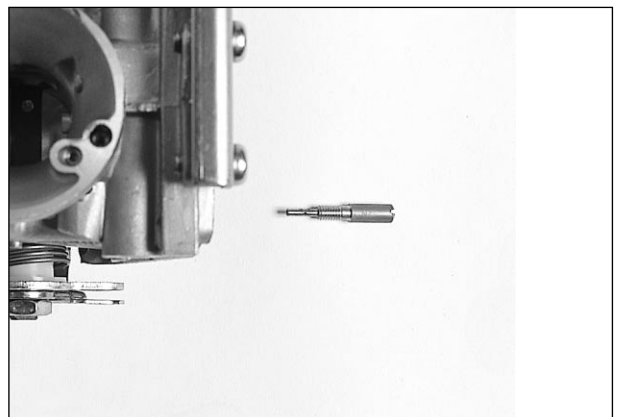

- Fit the seal rings securely to the float chamber and install the float chamber to the throttle body.
- Install the eight screw ①.

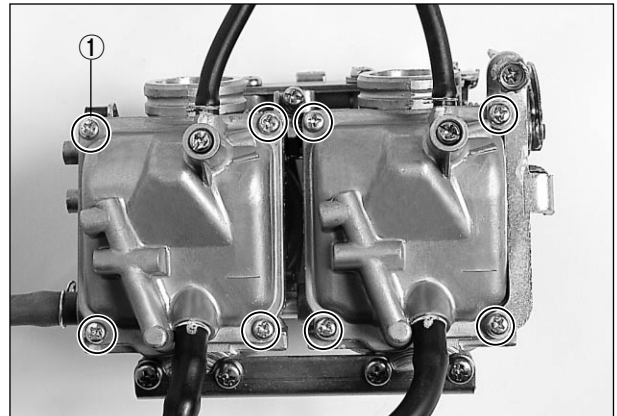

- Install the jet needle with the pin ② on the spacer securely engaged with the hole ③ on the piston valve.

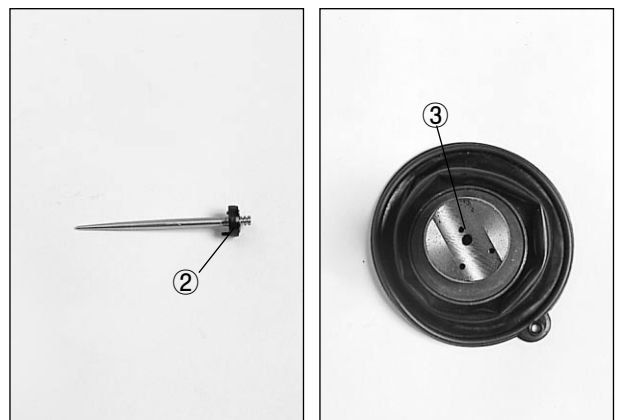

- Align the hole ④ of the diaphragm with passage way on the carburetor body.

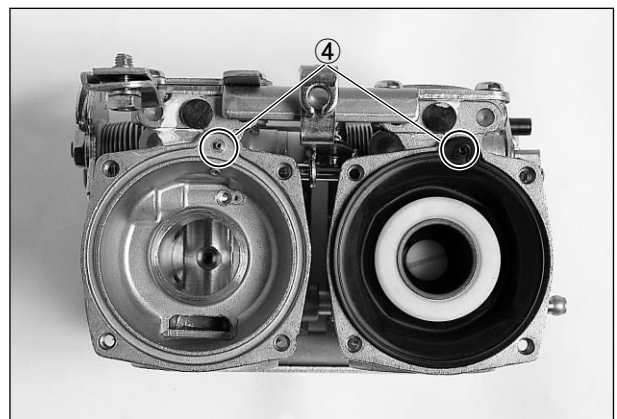

- Install the eight screw ⑤.



4-9 FUEL SYSTEM

⚠ CAUTION

Never adjust “CO adjust screw” **A** of the carburetor. If adjust at discretion, have a bad influence upon output of the engine as the two carburetor is disharmonious.

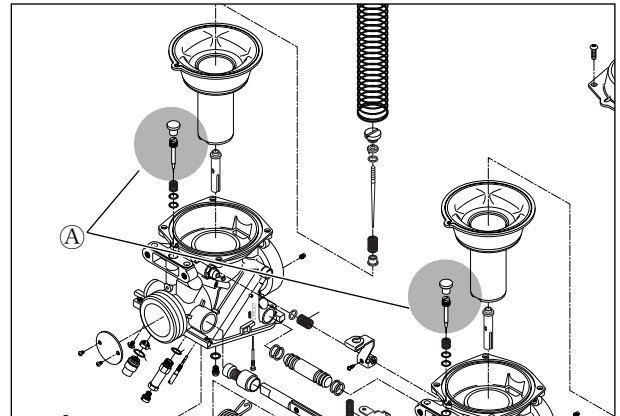

- After the assembly and installation on the engine have been completed, perform the following adjustment.

Throttle cable adjustment. (Refer to page 2-8)

Idle speed adjustment. (Refer to page 2-8)