

## FOREWORD

This manual is an essential part of your vehicle. Please read it carefully. It contains important information on safety, operation and maintenance. It is especially important that this manual remain with the vehicle at the time of resale. The next owner will need this information also.

Your **HYOSUNG 'ATV** is built for use by children, but this owner's manual is written for the adults who will be supervising the children. **HYOSUNG** strongly recommends, therefore, that you review this entire manual with your child and carefully explain the instructions, requirements, and warnings it contains so that your child can understand them.

## IMPORTANT

### WARNING/CAUTION/NOTE

Please read this manual and follow its instructions carefully. To emphasize special information the words 『**WARNING**』, 『**CAUTION**』 and 『**NOTE**』 have special meanings. Information following these signal words should be carefully reviewed.



### WARNING

**The personal safety of the rider or bystanders may be involved. Disregarding this information could result in personal injury.**



### CAUTION

**These instructions point out special service procedures or precautions that must be followed to avoid damaging the machine.**

***NOTE: This provides special information to make maintenance easier or important instructions clearer.***



**HYOSUNG MOTORS & MACHINERY INC.**

Overseas Technical Department

© COPYRIGHT HYOSUNG MOTOR & MACHINERY INC.

**This manual should be considered a permanent part of the vehicle and should remain with the vehicle when resold or otherwise transferred to a new owner or operator. The manual contains important safety information and instructions which should be read carefully before operating the vehicle.**

## IMPORTANT NOTICE TO PARENTS

### WARNING

- Even though the 'ATV' has four wheels, it can tip over in any direction. Improper turning techniques, traversing hills, accelerating on hills, and turning on hills can all lead to vehicle tip over. Learn proper riding techniques and avoid riding situations which can lead to tip over accidents.
- The 'ATV' and other all-terrain vehicles (ATVs) have unique handling characteristics. ATVs handle differently than motorcycles. Although ATVs have four(or three) wheels, they handle differently than automobiles, too. ATVs require special riding techniques suited to their handling characteristics, so be sure that all riders of the 'ATV' practice and master the riding techniques described in this owner's manual (Starting on page 15)

### WARNING

Proper parental supervision and instruction are necessary for safe and proper operation of this 'ATV' by young riders.

It is important that both you and your child understand and observe the restrictions listed on the fender label of the 'ATV'.

Read this owner's manual carefully and review its contents fully with your child. It is YOUR RESPONSIBILITY to make sure that your 'ATV' is properly and safely ridden and maintained.

### WARNING

You must take special precautions to reduce the chance of accidents and injuries resulting from operation of this vehicle. Some of the important safety precautions you should take are :

- Supervise operation of the 'ATV' AT ALL TIMES. Constant supervision is necessary so you can observe that the operator is riding safely.
- Never permit children under age 6 to operate the 'ATV'. These children, as well as some children age 6 and older, may not be able to operate this vehicle safely due to physical or mental limitations. Parents should carefully observe their child's first use of the vehicle. Further use should be permitted only if the parent can determine that the child has the physical and mental capabilities necessary to operate the vehicle safely.
- Before first use of the 'ATV', read this owner's manual carefully to become familiar with the 'ATV's' features, and safety and maintenance requirements. Review all instructions, requirements and warnings with the riders. Keep the owner's manual in the owner's manual storage compartment located under the seat.
- Before the rider's first use of the 'ATV', make sure that he/she is familiar with the location and operation of all controls, and has been instructed in the proper operation of the vehicle.
- For first use of the 'ATV', find a level, open area for the rider to use to become familiar with the operation of controls and the operating and handling characteristics of the 'ATV'.

- **Before each use, perform daily inspections with the rider. Specific items to check are listed in the INSPECTION BEFORE RIDING section on page 15 of this owner's manual.**
- **Make sure the rider wears a helmet, eye protection, and protective clothing (gloves, leather or heavy cloth pants, long sleeved shirt or jacket, boots).**
- **Beware of hazardous situations. Instruct the rider to do likewise.**
- **Do not permit the 「ATV」 to be used on public roads AT ANY TIME.**  
This vehicle is designed and manufactured for use **ONLY** off public roads. It is not subject to Federal Motor Vehicle Safety Standards as it is not equipped or approved for operation on public streets, roads, or highways at any time.
- **Do not permit the 「ATV」 to be operated on any paved surfaces. The vehicle can be more difficult to control when it is operated on pavement.**
- **Permit use only by a single rider. This vehicle is designed for use only by a single rider. Extra seat space is provided so the rider can change his/her body position to maneuver the vehicle. This space should never be used to carry a passenger.**
- **Do not permit anyone to operate the 「ATV」 while under the influence of alcohol or other drugs.**
- **Make sure the combined weight of the rider, protective gear and any accessories or cargo does not exceed the 35kg(77lbs) weight limit. Exceeding this weight limit may result in injury caused by damage to the vehicle or altered handling characteristics.**

- **Observe periodic maintenance requirements-your authorized HYOSUNG dealer is trained and equipped to perform this service.**
- **Never permit vehicle refueling by anyone other than an adult.**
- **Drain gasoline from the fuel tank and carburetor prior to transporting the 「ATV」.**
- **Caution the rider and others near the 「ATV」 not to get close to or touch any moving parts or any heated areas such as the engine and exhaust system.**
- **Do not make any modifications to the 「ATV」. Modifications may make the vehicle unsafe or illegal unsafe or illegal in your state.**
- **Do not allow the 「ATV」 to be ridden at night. This vehicle is not equipped with a headlight. Unseen obstacles could cause an accident resulting in injury to the rider.**

# TABLE OF CONTENTS

1. SERIAL NUMBER LOCATION.....	5
2. FUEL AND OIL RECOMMENDATIONS.....	5
<b>FUEL</b>	
<b>ENGINE OIL</b>	
<b>TRANSMISSION OIL</b>	
3. LOCATION OF PARTS .....	6
4. CONTROLS .....	10
<b>LEFT HANDLEBAR</b>	
<b>RIGHT HANDLEBAR</b>	
<b>FUEL COCK</b>	
5. EQUIPMENT AND ADJUSTMENTS .....	12
<b>FUEL TANK CAP</b>	
<b>REMOTE ENGINE STOP SWITCH</b>	
6. BREAK-IN (RUNNING-IN) .....	14
7. INSPECTION BEFORE RIDING .....	15
8. RIDING TIPS .....	15
9. INSTRUCTING THE YOUNG RIDER .....	21
10. INSPECTION AND MAINTENANCE .....	24
<b>MAINTENANCE SCHEDULE</b>	
<b>PERIODIC MAINTENANCE CHART</b>	
<b>SEAT REMOVAL</b>	
<b>TOOLS</b>	
<b>AIR CLEANER</b>	
<b>SPARK PLUGS</b>	
<b>IDLE SPEED ADJUSTMENT</b>	
<b>THROTTLE CABLE ADJUSTMENT</b>	
<b>FUEL HOSE</b>	
<b>TRANSMISSION OIL</b>	
<b>ENGINE OIL LEVEL</b>	

<b>BRAKE</b>	
<b>TIRES</b>	
<b>DRIVE CHAIN</b>	
<b>FOOTREST HEIGHT ADJUSTMENT</b>	
<b>FRONT AND REAR WHEEL REMOVAL</b>	
<b>GENERAL LUBRICATION</b>	
11. TROUBLESHOOTING .....	39
12. TRANSPORTING .....	40
13. CLEANING PROCEDURE .....	41
14. STORAGE PROCEDURE .....	43
15. LOCATION OF LABELS .....	44
16. SPECIFICATIONS .....	46

## SERIAL NUMBER LOCATION

The frame and/or engine serial numbers are used to title the vehicle. They are also used to assist your dealer when ordering parts or referring to special service information.

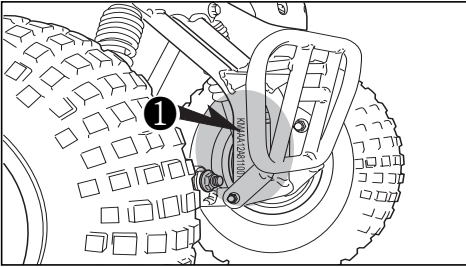

The frame number ① is stamped on the front frame member as shown in the illustration.

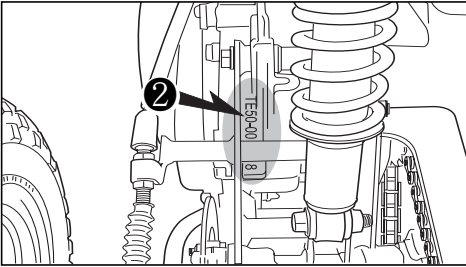

The engine serial number ② is stamped on the left side of the crankcase assembly.

Please write down the serial numbers here for your future reference.

Frame No.:

Engine No.:

## FUEL AND OIL RECOMMENDATIONS

### FUEL

Gasoline used should be graded 85 ~ 95 octane or higher. An unleaded type gasoline is recommended. If engine pinging is experienced, substitute another brand as there are differences between brands.

### ENGINE OIL

Use **HYOSUNG HYPOL OIL HS.**

If they are not available, use a good quality TWO-STROKE engine oil.

### TRANSMISSION OIL

Use a good quality SAE 10W/40 multi-grade motor oil.

---

## LOCATION OF PARTS

---

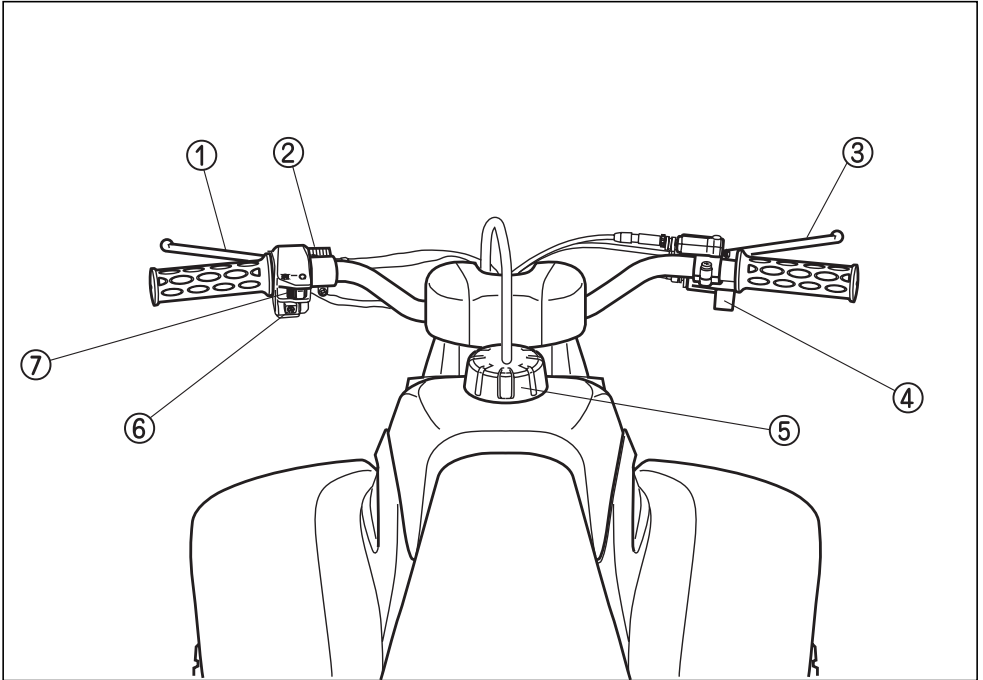

- ① Rear brake lever (Parking brake lever)
- ② Parking brake knob
- ③ Front brake lever
- ④ Throttle lever
- ⑤ Fuel tank cap
- ⑥ Starter switch
- ⑦ Engine stop switch

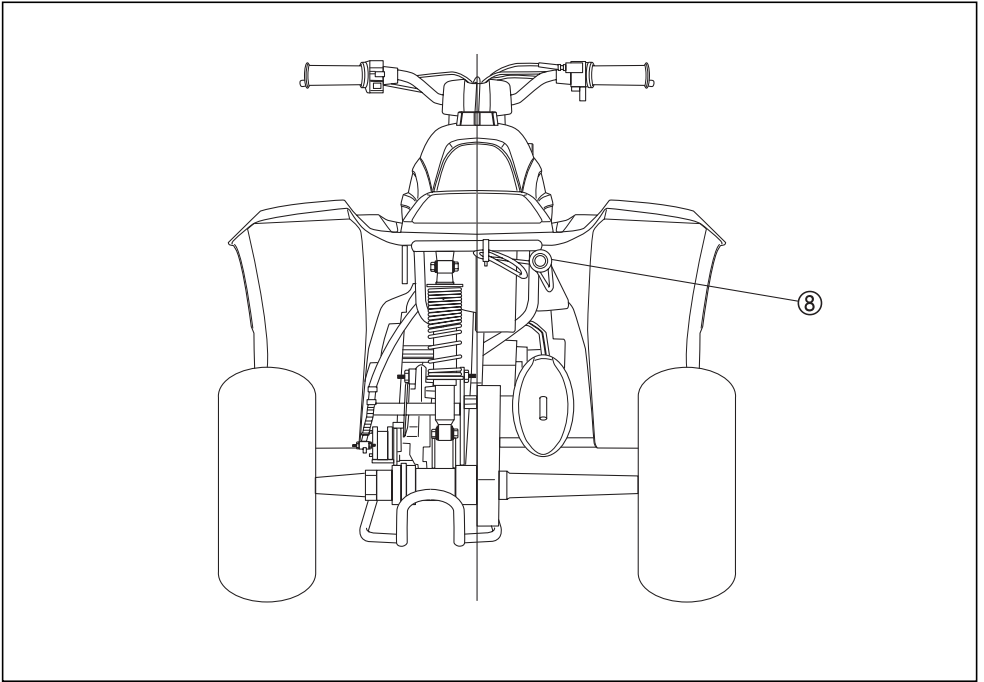

⑧ Remote engine stop switch

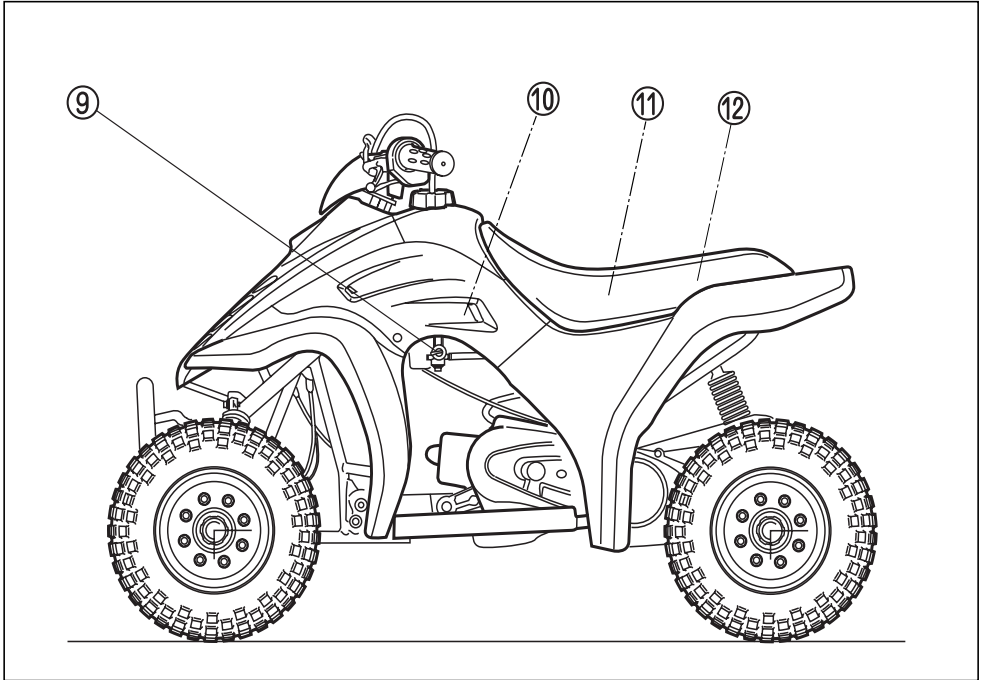

- ⑨ Fuel cock
- ⑩ Air cleaner
- ⑪ Battery & fuse
- ⑫ Tools



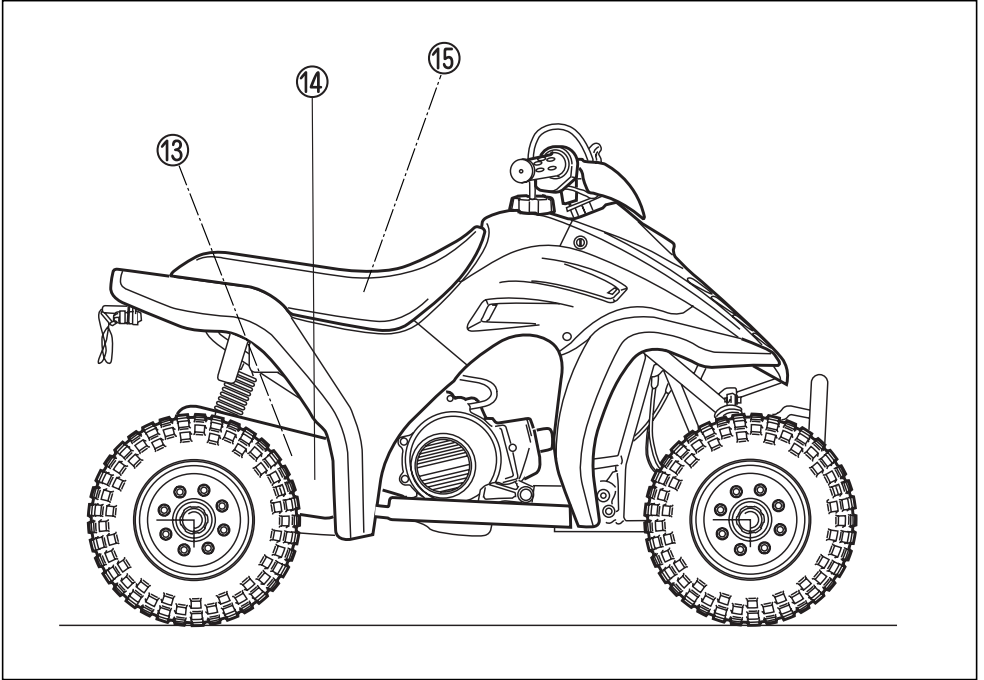

- ⑬ Drive chain
- ⑭ Muffler
- ⑮ Engine oil tank

## CONTROLS

### LEFT HANDLEBAR

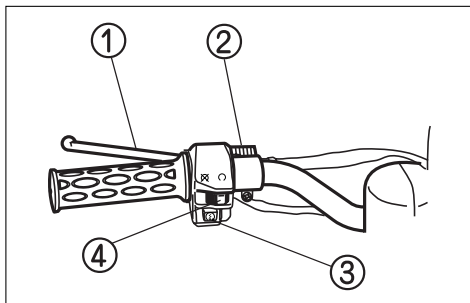

#### ① Rear Brake Lever

Apply the rear brake by squeezing the rear brake lever towards the grip.

#### ② Parking Brake Knob

This knob is used to set the parking brake, which is used to prevent the 『ATV』 from moving when it is parked, being started, or at idle. Set the parking brake by squeezing the rear brake lever and pushing this knob to lock the lever in the squeezed position.

#### ③ Starter Switch



Push in the electric starter switch to rotate the starting motor.

**NOTE :** If the front or rear brake lever is not squeezed, the starter motor will not rotate.

### CAUTION

When the starter motor doesn't rotate within 5 seconds after pushing the switch, try again after 10 seconds to prevent damage to the battery.

#### ④ Engine Stop Switch

- ④ “” **Position :** The ignition circuit is off.  
The engine cannot start or run.
- ④ “” **Position :** The ignition circuit is on and the engine can run.

### RIGHT HANDLEBAR

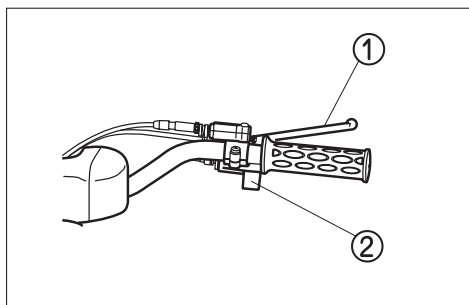

#### ① Front Brake Lever

Apply the front brake by squeezing the front brake lever towards the grip.

#### ② Throttle Lever

Engine speed is controlled by the position of the throttle lever. Push it forward to increase engine speed. Release it to decrease engine speed. This lever is operated by the rider's thumb.

#### ③ Throttle Limiter

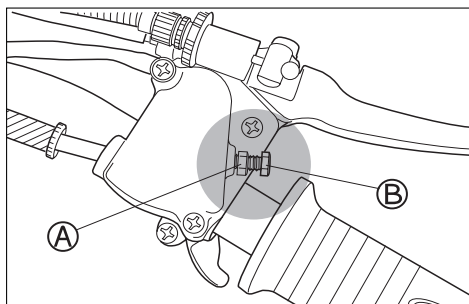

This vehicle is equipped with the throttle limiter to restrict maximum engine power by limiting throttle lever travel. The supervising adult should adjust this limiter to limit maximum vehicle speed according to the rider's skill and experience.

To adjust the throttle limiter :

1. Loosen the lock nut **A**.
2. Turn the throttle limiter screw **B** clockwise to restrict maximum engine power or counterclockwise to increase maximum engine power.
3. Tighten the lock nut **A**.

## FUEL COCK

This vehicle is equipped with a manually operated fuel cock.

There are three positions : ON , OFF and RES

### ⦿ "ON" Position

The normal operating position for the fuel cock lever is in the "ON" position.

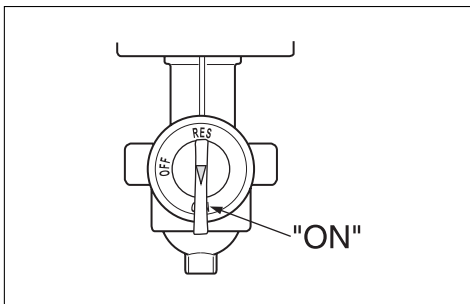

### ⦿ "OFF" Position

Turn the lever to the "OFF" position whenever stopping the engine for more than a few minutes.

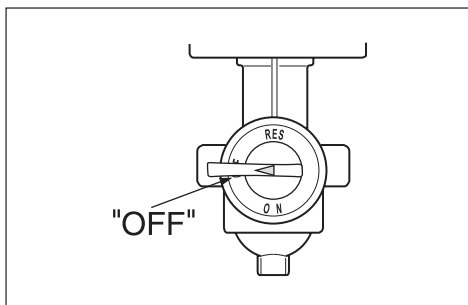

### ⦿ "RES" (RESERVE) Position

If the fuel level in the tank is too low, turn the lever to the "RES" position to use the 1 ℓ of reserve fuel supply.

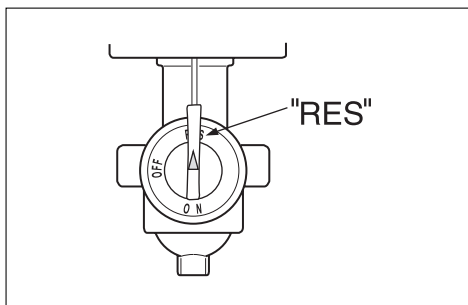

## CAUTION

**After switching the fuel cock lever to the "RES" position, it is advisable that the tank be refilled at the closest gas station.**

**After refueling be sure to move the fuel cock to the "ON" position.**

## EQUIPMENT AND ADJUSTMENTS

### FUEL TANK CAP

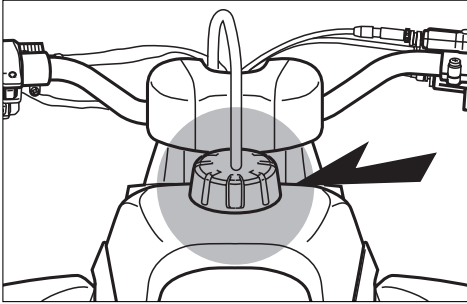

To open the fuel tank cap, remove the end of the vent tube from the hole in the vehicle body and turn the fuel tank cap counterclockwise. To close the fuel tank cap, turn it clockwise and tighten it securely. Be sure that the end of the vent tube is reinstalled in the hole in the vehicle body and routed properly as shown.

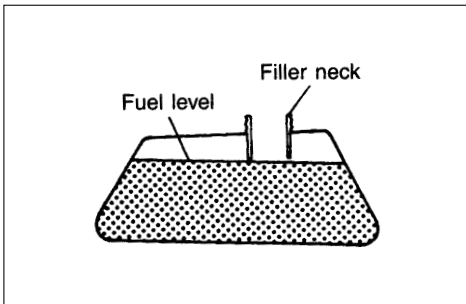

### WARNING

**Do not overfill the fuel tank. Stop adding fuel when the fuel level reaches the bottom of the filler neck as shown the illustration. If you fill the tank beyond this level, fuel may overflow when it expands due to engine heat or heating by the sun.**

### WARNING

**Gasoline is extremely flammable and toxic. Always observe the following precautions when refueling your «ATV».**

- Never permit vehicle refueling by anyone other than an adult.
- Refuel in a well ventilated area.
- Make sure the engine is off and avoid spilling fuel on a hot engine.
- Do not smoke, and make sure there are no open flames or sparks in the area.
- Avoid prolonged contact with skin and breathing of gasoline vapors.
- Keep children and pets away during refueling.

### REMOTE ENGINE STOP SWITCH

The «ATV» comes equipped with a remote engine stop switch which may be operated by pulling the leash-like lanyard attached to the remote engine stop switch cap. An adult supervising operation of the vehicle can use the lanyard to stop the engine from a short distance. The adult who trains the young rider should always use this lanyard until the rider develops sufficient skills for safe operation of the vehicle.

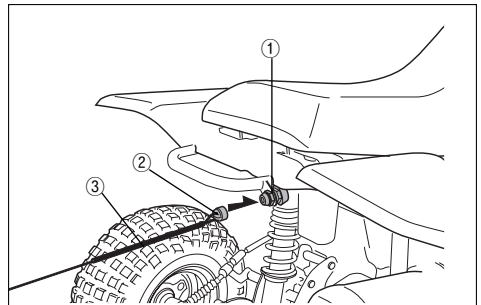

- ① Switch body
- ② Rubber cap
- ③ Remote engine stop switch lanyard

The switch consists of a rubber cap fitted over a plastic body. When the rubber cap is in place, the engine can operate. When the rubber cap is removed from the switch body, the engine cannot be started. If the engine is running and the rubber cap is removed by pulling the lanyard attached to the cap, the engine will stop running.

To use the remote engine stop switch :

1. Fit the rubber cap on the engine of the lanyard over the remote engine stop switch body located on the rear end of the vehicle as shown.
2. Put your fingers through the loop at the other end of the lanyard.

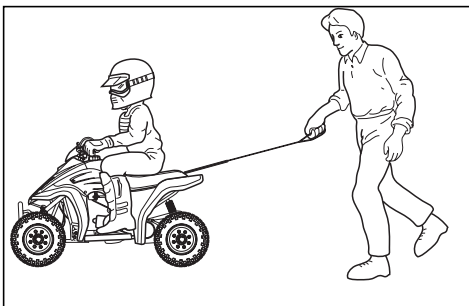

3. With the lanyard fastened to the vehicle and to your hand, follow after the moving vehicle. If you notice any driving hazard or unsafe situation, pull the lanyard forcefully so that the rubber cap comes off. This will activate the remote engine stop switch, stopping the vehicle's engine.

### **WARNING**

**When the remote engine stop switch cap is pulled off, the engine will stop running. The vehicle will continue to roll for some distance, however. Remember this when judging when to operate the remote engine stop switch.**

### **WARNING**

**If you do not put your fingers through the loop in the lanyard, it may slip from your grasp unexpectedly. This could make it impossible for you to stop the engine in an unsafe situation.**

### **WARNING**

**The throttle limiter should always be set to the low power position (as described on page 10) when the remote engine stop lanyard is used. Only children with enough skill for safe operation of the 'ATV' without parental use of the lanyard should be permitted to operate 'ATV' with the throttle limiter set to the maximum power position. In addition, an adult trying to follow a moving 'ATV' with the throttle limiter set to the maximum power position may run into the rider if he stops, or may trip and fall down trying to keep up with the vehicle.**

### **Instruction For Remote engine stop switch Lanyard Storage**

The lanyard may be stowed on the 'ATV' when, in the judgement of the parents, the rider has developed sufficient skills to be able to safely operate the vehicle without parental use of the lanyard.

For storage of the lanyard, follow the instructions below :

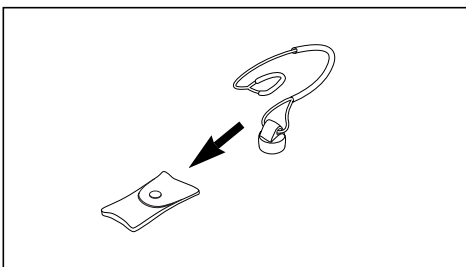

1. Place the lanyard in the vinyl bag provided with the vehicle, with the rubber cap visible at the bag opening.

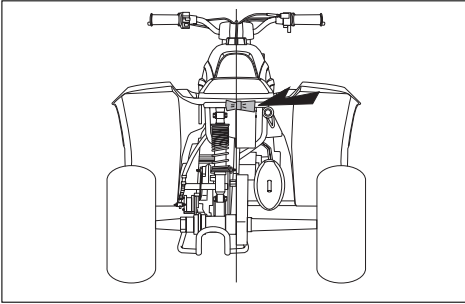

2. Hook the bag on the frame as shown and fit the rubber cap snugly over the remote engine stop switch body.

**NOTE :** *With the rubber cap off the switch, the engine can not be started because the ignition circuit is not completed.*



## **WARNING**

**Avoid leaving any part of the lanyard visible outside the bag as it can be caught and damaged by moving parts.**



## **WARNING**

**To prevent unauthorized starting or unsupervised operation of the 'ATV', remove the remote engine stop switch cap and lanyard after each use and store them in a safe place, out of the reach of children.**

## **BREAK-IN (RUNNING-IN)**

The first month is the most important in the life of your vehicle. Proper operation during this break-in period will help ensure maximum life and performance from your new vehicle. The following guidelines explain proper break-in procedures.

### **★ MAXIMUM THROTTLE OPENING RECOMMENDATION**

During the first 10 hours of vehicle operation, the maximum throttle opening you should use is 1/2 throttle.

### **★ VARY THE ENGINE SPEED**

The engine speed should be varied during the break-in period. Although it is essential that some stress be placed on the engine components during break-in, you must be careful not to excessively load the engine.

### **★ AVOID CONSTANT LOW SPEED**

Operating the engine at constant low speed (light load) can cause parts to glaze and not seat properly. Allow the engine to accelerate freely through the gears, without exceeding the maximum recommended throttle opening.

### **★ OBSERVE YOUR INITIAL AND MOST CRITICAL SERVICE**

The initial service (break-in maintenance) is the most important service your vehicle will receive. During break-in operation, all of the engine components will have mated together and seated. Maintenance required as part of the initial service includes correction of all adjustments, tightening of all fasteners and replacement of dirty oil.

Timely performance of this service will ensure optimum service life and performance from the engine.



## **WARNING**

**The initial service (after 1 month of vehicle operation) should be performed as outlined in the INSPECTION AND MAINTENANCE section of this Owner's Manual. Pay particular attention to the information contained in the CAUTION and WARNING section when performing this maintenance.**

## INSPECTION BEFORE RIDING

WHAT TO CHECK	CHECK FOR :
Steering	No rattle or looseness
Brakes	<ul style="list-style-type: none"> <li>● Proper lever play</li> <li>● Parking brake effectiveness</li> </ul>
Tires	<ul style="list-style-type: none"> <li>● Proper pressure</li> <li>● Enough tread depth</li> <li>● No cracks, rips, or other damage</li> </ul>
Fuel	<ul style="list-style-type: none"> <li>● Enough fuel for the intended run</li> <li>● Fuel hose connected securely</li> <li>● No damage to fuel tank or cap</li> <li>● Tank cap closed securely</li> </ul>
Engine stop switch	Proper operation
Engine oil	Proper level
Transmission oil	Proper level
Throttle	<ul style="list-style-type: none"> <li>● Proper cable play</li> <li>● Smooth response</li> <li>● Quick return to idle position</li> </ul>
Drive chain	Adequate lubrication
General condition	<ul style="list-style-type: none"> <li>● Bolts and nuts are tight</li> <li>● No rattle from any part of the machine with the engine running</li> <li>● No visible evidence of damage</li> </ul>
Remote engine stop switch (if used)	<ul style="list-style-type: none"> <li>● Proper operation</li> <li>● No damage to rubber cap</li> <li>● Secure attachment of lanyard to cap</li> </ul>

### **WARNING**

**Failure to perform an inspection before riding may result in an accident or serious damage to the vehicle. Check these items before each ride. Be sure your 'ATV' is in good condition for the personal safety of the rider and protection of the vehicle.**

### **WARNING**

**All of the items above should be checked with the engine off, except the functional check of the remote engine stop switch. Make sure your child doesn't get too close when you check the fuel level and drive chain, or he/she might be injured.**

## RIDING TIPS

### ★ **DO NOT START THE 'ATV,' OR ALLOW YOUR CHILD TO RIDE YET**

Finish reading the Riding Tips section and then the Instructing the Young Rider section before starting the 'ATV,' or beginning riding instructions. The Riding Tips section contains important operating information you will need to know before you go to the Instructing the Young Rider section. The Instructing the Young Rider section will guide you in teaching young riders how to operate and ride the 'ATV,' using the information you learn in this owner's manual.

### ★ **STARTING THE ENGINE**

Before attempting to start the engine, make sure:

1. The parking brake is engaged.
2. The engine stop switch is in the  position.
3. Verify that the remote engine stop switch cap is in place.
4. The fuel cock is in the ON position.

 **WARNING**

- **Do not run the engine indoors or where there is little or no ventilation. Exhaust gases contain carbon monoxide, a potentially lethal gas that is colorless and odorless.**
- **Never leave the vehicle running while unattended, even for a short time.**

★ **STARTING OFF**

After the engine has warmed up, disengage the parking brake. To release the parking brake, simply squeeze the brake lever until the lock knob disengages.

 **WARNING**

**Before releasing the parking brake, make sure:**

- **The throttle is fully closed.**
- **The rider is completely ready to ride.**

**If you do not observe these precautions, the vehicle can move forward unexpectedly when the parking brake is released. This may result in an accident and injury.**

Open the throttle gradually to move forward.

 **WARNING**

**While operating the 「ATV」, the rider should keep both feet on the footrests at all times, or injuries resulting from accidents such as the rear wheels running over the rider's feet could occur. There is no need for the rider to move his/her feet from the footrests during operation or maneuvering of the vehicle. Moving the rider's feet from the footrests reduces the rider's ability to control the vehicle, and could lead to an accident.**

 **WARNING**

**Keep both hands on the handgrips at all times when riding. Removing your hands from the handgrips reduces your ability to control the vehicle, and could result in an accident.**

 **WARNING**

**Always open the throttle gradually to prevent front wheel lifting. Failure to observe this precaution may result in loss of control and an accident.**

★ **BRAKING**

To stop the 「ATV」, release the throttle lever and apply the brake.

 **WARNING**

- **Avoid braking during turns. Use of the brake when turning could cause the 「ATV」 to slide or roll over. Use the brake to slow down before entering turns.**
- **Apply the brake lightly and with great care on slippery surfaces to avoid skidding.**

 **WARNING**

**Never operate the parking brake lock when the 「ATV」 is moving. The rear wheels will lock, and an accident could result.**



## ★ TURNING

To turn the **'ATV'**, the rider must learn a special technique. Because this vehicle has a solid rear axle, both rear wheels always turn at the same speed. This means that if the rear wheels are getting equal traction, the vehicle will move straight ahead, because the rear wheels will travel the same distance.

For the vehicle to turn, the outside rear wheel must travel a greater distance than the inside rear wheel. To make this happen, the rider must learn how to create less traction for the inside wheel, so that it can travel a shorter distance than the outside wheel, even though both wheels are still turning at the same speed.

To turn the **'ATV'**, the rider should use the following technique :

- Turn the handlebars in the direction of the turn.
- Shift body weight slightly forward and support your weight on the outer footrest. This will reduce the load on the inside rear wheel, reducing its traction.
- Lean upper body into the turn.

### ■ At higher speeds :

Use the same technique that you use for turning at low speeds, but lean farther into the turn. Since natural turning forces(which tend to push the vehicle to the outside of the turn) increase as speed increases, you must lean your upper body farther into the turn as you go faster, to prevent the vehicle from tipping over to the outside of the turn. Remember, though, to keep your weight supported on the outer footrest.

## WARNING

**If the rider does not use the proper technique to turn the 'ATV', it may plow straight ahead even though the front wheels are turned. The rider should practice the above technique at low speeds in a wide open area until he/she has mastered it.**

## ★ SKIDDING OR SLIDING

If the rider experiences inadvertent skidding or sliding when not braking, he/she may be able to overcome it by using the appropriate technique listed below.

### ■ Front wheel:

If front wheel skidding occurs, try to gain front wheel traction by reducing the throttle opening and leaning your body weight slightly forward.

### ■ Rear wheel

If rear wheel skidding occurs, steer in the direction of the skid (if space permits), shift body weight away from the skid slightly, and avoid using the throttle or brakes until you regain directional control of the vehicle.

## WARNING

**Skidding or sliding can result in accidents caused by loss of rider control. To avoid inadvertent skidding or sliding, the rider should slow down and be very cautious when riding on slippery or loose surfaces.**

## ★ OPERATION ON HILLS

Riders who have become experienced at operating the 'ATV' on level surfaces may wish to try riding on a wider variety of terrains. The 'ATV' may be operated on small hills with even surfaces, but extreme care should be taken.

### WARNING

**When the 'ATV' is operated on hills, it can roll over more easily than when it is operated on level ground, under certain conditions. Only children who are capable of safe operation of the 'ATV' on level ground should be permitted to operate the vehicle on hills.**

### ■ Climbing a Hill

To climb a small hill with the 'ATV', the rider should:

- Speed up and maintain a steady speed before reaching the bottom of the hill.
- Shift body weight forward by sliding forward on the seat. Lean slightly forward.
- Maintain a steady speed while climbing the hill.
- Slow down when reaching the top of the hill.

### WARNING

**Only permit your child to climb small hills. Do not let him/her attempt to climb a hill unless you are sure that he/she can easily ride to the top of the hill without stopping. It can be dangerous to stop the 'ATV' while climbing a hill, because the vehicle may begin to roll backwards and then roll over.**

### WARNING

**The rider should never open the throttle suddenly when climbing a hill. The vehicle could flip over backwards.**

### WARNING

**The rider should never go over the top of the hill at high speed. Once over the top of the hill, he/she could lose control and crash or could collide with an unseen object.**

If your child is climbing a hill and loses forward momentum, he/she should :

- Lean farther forward, uphill.
- Apply the front and rear brake and stop the vehicle before it starts to roll backwards.
- Set the parking brake and dismount to the right while still leaning uphill.
- Use one of the following procedures to turn the vehicle around :

1. Ask the adult who is supervising to help drag the rear end of the **'ATV'** around until the vehicle is angled downhill. Stay on the uphill side of the vehicle while dragging it around.
  2. Turn the handlebars fully to the right. While standing on the uphill side of the vehicle, release the parking brake and pump the hand brake to let the **'ATV'** roll slowly backwards. This will turn the vehicle sideways to the hill. Reset the parking brake. Turn the handlebars to the left. Staying on the uphill side, release the parking brake and pump the hand brake to let the ATV roll until it is angled downhill. Reset the parking brake.
- Remount the vehicle, release the parking brake and ride down the hill as instructed in the DESCENDING A HILL section.

 **WARNING**

**The rider should never allow the 'ATV' to roll backwards on a hill. If the vehicle does begin to roll backwards, the rider should move his/her body weight forward and try to slow the vehicle to a stop using the FRONT BRAKE ONLY. If the front brake does not slow the vehicle, the rider should dismount to the side immediately. The rear brake should never be used when rolling backwards on a hill. Use of the rear brake can cause the vehicle to flip over.**

**■ Descending a Hill**

To ride down a small hill with the **'ATV'**, the rider should:

- Point the **'ATV'** straight downhill.
- Transfer body weight to the rear by sliding back on the seat.
- Ride down the hill with the throttle closed.
- Apply the brake to control downhill speed.

**■ Traversing a Slope**

 **WARNING**

**Traversing a slope is very tricky and should be avoided when possible. Improper riding techniques while traversing a slope could cause the 'ATV' to tip over. Do not permit your child to traverse a slope unless you are sure he/she can perform this maneuver safely.**

To traverse a slope, the rider should:

- Lean his/her body uphill.
- Steer slightly uphill, if necessary, to maintain a straight course.

### ★ RIDING THROUGH WATER

The **ATV** may be ridden through water, provided that it is not more than 15cm (6 in) deep and is not moving fast. When crossing a stream, choose a spot where the banks are gently sloped on both sides and the bottom of the stream is hard. If you are unfamiliar with the area you wish to cross, park the **ATV** and inspect the stream first, to find a suitable spot for crossing. When crossing, operate the vehicle at a slow, steady speed.



#### WARNING

- **Do not attempt to cross a stream with deep or fast flowing water. The tires may lose their traction, and you may be unable to control the vehicle. This could result in personal injury.**
- **After riding through water, test the brakes to see if they have maintained their normal effectiveness. If they are less effective than normal, dry them by repeatedly applying the front and rear while riding slowly until the brakes have regained their normal effectiveness.**



#### CAUTION

**After extended operation of the **ATV** in water, bring it to your authorized HYOSUNG dealer to have the brakes inspected and cleaned, if necessary. Failure to take this precaution can result in excessive brake wear.**

### ★ STOPPING THE ENGINE

Release the throttle lever. Turn the engine stop switch to the  position.

### ★ PARKING THE VEHICLE

Set the parking brake securely as explained in the STARTING THE ENGINE section.



#### WARNING

**It takes some time for the engine and muffler to cool off after a long ride. Do not touch these parts until they have had time to cool off, or you may burn yourself.**

## INSTRUCTING THE YOUNG RIDER

### ★ IMPORTANT ADVICE TO THE PARENT :

Your child's safety depends on your commitment to take the time necessary to fully educate him/her on the proper operation of the **'ATV'**. Remember that proper instruction before your child begins to ride is just as important as proper instruction and supervision during riding.

Please go through this manual with your child, page by page, and fully explain all of the instructions, requirements and warnings it contains. Be sure to put as much emphasis on safety precautions as on proper operational techniques. Question your child as you go through the manual to make sure he/she understands what you are saying.

Following is a step by step guide to help make your child's first use of the **'ATV'** a safe and enjoyable experience. Before you begin to use this guide, however, be sure you have reviewed the vehicle features and riding techniques described in earlier parts of this owner's manual, HYOSUNG strongly urges that you use this guide to teach each child that you let ride the **'ATV'**.

Be sure to take breaks as the child being instructed gets tired or his/her attention begins to wander. Full attention at all times is needed to safely operate any motorized vehicle, including the **'ATV'**.

### ■ STEP 1 - PROPER CLOTHING AND PROTECTIVE GEAR

The first step to safe riding is proper protection of the rider. Your child should always wear a helmet, eye protection, gloves, long pants, a

long sleeved shirt or jacket, and boots.

Make sure that your child is not wearing any loose fitting clothes. Loose belts, scarves, etc. can get caught in moving parts and cause personal injury. Even in hot weather, make sure your child wears long pants and a long sleeved shirt. These not only protect against abrasive injuries, but also help to reduce fatigue which comes from loss of body heat due to the wind.



### WARNING

**Failure to wear proper clothing and protective gear, as described above, may result in severe personal injury.**

### ■ STEP 2 - FAMILIARIZATION WITH THE VEHICLE

Your child should become completely familiar with the names and functions of all controls. Let the young rider sit on the **'ATV'**, with the engine off, and ask him/her to operate specific controls. Demonstrate operation of the controls if necessary. Ask the child to do such things as apply the brakes, turn off the engine, lock the parking brake, etc. Practice this exercise until the child can operate all of the controls without hesitation and without looking at the controls.

Go over the INSPECTION BEFORE RIDING with your child until he/she knows all of the items that should be checked and how they should be checked. Give specific examples of things to look for.

### ■ STEP 3 - STARTING OFF AND STOPPING



#### WARNING

**For practice, choose a large, level area away from other riders and free of obstructions. Inspect the area before riding and remove any rocks, sticks or other potential hazards. Stay away from ditches and bumps.**

To help your child develop confidence, he/she should PRACTICE FIRST WITH THE ENGINE OFF, as follows :

1. Have your child sit on the 『ATV』 and tell him/her to release the parking brake.
2. Instruct your child to keep his/her eyes straight ahead and slowly push the vehicle from behind, if you are physically able to do so. This will allow your child to get the feel of riding a moving vehicle.
3. As you push the 『ATV』, instruct your child to steer straight ahead and perform operations such as stopping the vehicle and turning off the engine stop switch while moving. Watch your child closely to make sure he/she is operating the controls correctly and without looking at the controls.
4. As you approach the end of the practice area, tell the rider to stop the vehicle, apply the parking brake, and get off. You should then drag the rear end of the 『ATV』 around so you can push it straight ahead in the opposite direction.

Practice with the engine off until your child gets the feel of using the brakes and can stop the vehicle and turn off the engine stop switch without looking at the controls, and without hesitation.



#### WARNING

**Before permitting your child to operate the 『ATV』 under power, be sure to adjust the throttle limiter to provide a low maximum speed capability. Turning the limiter clockwise reduces the 『ATV』's maximum speed capability.**

Next, start the 『ATV』's engine and have your child practice starting off, riding in a straight line, and stopping, with the vehicle under power.

Walk along the side of the ATV if you can, or have the young-ster ride back and forth between you and another supervisor.

Watch closely to make sure the rider :

1. Opens the throttle gently when starting off.
2. Releases the throttle and applies the brake in sequence when stopping.
3. Becomes aware of the distance it takes the vehicle to stop when the engine stop switch is turned off while the vehicle is moving.

As you approach the end of the practice area, you should again tell the rider to stop the vehicle, apply the parking brake, and get off so you can turn it around for him/her. Practice this exercise until your child can start off, accelerate, cruise and stop correctly and with confidence.

## ■ STEP 4 - TURNING

After your child has learned to ride the **'ATV'** in a straight line and can stop it when he/she wants to, you should teach the child how to turn the vehicle.

Explain the proper body movements for turning, and let your child **PRACTICE FIRST WITH THE ENGINE OFF**, as you push the vehicle from behind.

When turning, watch to make sure your child:

1. Shifts his/her weight slightly forward and supports his/her weight on the outer footrest.
2. Leans his/her upper body into the turn and turns the handlebars in the direction of the turn.

When the rider is able to properly turn the **'ATV'** in both directions with the engine off, he/she should practice with the vehicle under power. Again, make sure that the throttle limiter is adjusted to provide a low maximum speed capability. Watch closely to make sure the rider is using the proper turning technique. The rider should practice turning until he/she can do it correctly and with confidence.

## ■ STEP 5 - PUTTING IT ALL TOGETHER

When your child has mastered the basic riding maneuvers in the previous steps, he/she should practice putting them all together. Instruct the rider to perform various maneuvers such as turning right, turning left, stopping, parking, etc. Mix up the order of these maneuvers so the child will not know what he/she will be asked to do next. Practice this exercise until you are confident that the rider has mastered all the basic maneuvers.

The above steps will help the first time rider learn the most basic riding techniques. To become a skilled rider, your child will need a great deal of practice and instruction after these steps have been completed. Be patient with your child; take extra time when teaching him/her additional techniques such as the recommended techniques for climbing and descending hills.

After your child has mastered all of the basic riding techniques at slow speeds, you can adjust the throttle limiter to provide higher speed capabilities, according to the rider's skill and experience.

## INSPECTION AND MAINTENANCE

### MAINTENANCE SCHEDULE

It is very important to inspect and maintain your **「ATV」** regularly. Follow the chart below. If indicates the intervals between periodic services in months. At the end of each interval, be sure to inspect, adjust, lubricate, replace and service as indicated.

#### WARNING

**HYOSUNG recommends that maintenance on those items in the chart below which are marked with an asterisk(\*) be performed by your authorized HYOSUNG dealer or a qualified service mechanic. If you are qualified, you may perform maintenance on the unmarked items by referring to the instructions in this section. If you are not sure whether you can successfully complete any of the unmarked maintenance jobs, ask your authorized HYOSUNG dealer to do the maintenance for you.**

#### WARNING

**Do not attempt to perform maintenance on this vehicle if you are not qualified. You could be injured or may damage the machine.**

#### WARNING

**The safety of the rider depends on how well this machine is maintained. Follow all inspection and maintenance instructions carefully.**

#### WARNING

**Don't let your children tinker with this machine. They may get hurt. Maintenance should only be performed by qualified adults. Make sure that the engine stop switch is in the “” position unless the engine must be running to perform the required maintenance.**

#### CAUTION

**The maintenance intervals shown in the chart below are based on average riding conditions. If the **「ATV」** is ridden in a dusty area, the air cleaner and drive chain should be serviced more frequently than shown in the chart. All items should be serviced more frequently if the vehicle is operated under extreme conditions. If you have any questions regarding appropriate maintenance intervals, consult your authorized HYOSUNG dealer.**



## PERIODIC MAINTENANCE CHART

### ○ ENGINE

Interval Item	Initial 1 month	Every 3 months	Every 6 months
<b>Air cleaner element</b>	Clean at least every month		
<b>Cylinder head nuts*</b>	Tighten	Tighten	—
<b>Cylinder head and cylinder*</b>	—	—	Remove carbon
<b>Carburetor</b>	Inspect	—	Inspect
<b>Spark plug</b>	Clean	Clean	Replace
<b>Fuel line</b>	Inspect	Inspect	—
	Replace every 4 years		
<b>Transmission oil</b>	Replace	—	Replace
<b>Drive chain</b>	Inspect and lubricate every month		
<b>Sprockets*</b>	Inspect	Inspect	—

### ○ CHASSIS

Interval Item	Initial 1 month	Every 3 months	Every 6 months
<b>Brakes</b>	Inspect	Inspect	—
<b>Steering*</b>	Inspect	Inspect	—
<b>Tires</b>	Inspect every month · Check pressure each time ride		
<b>Chassis nuts and bolts*</b>	Tighten	Tighten	—
<b>General lubrication*</b>	—	Lubricate	—

### CAUTION

**More frequent servicing may be performed on motorcycles that are used under severe conditions.**

### **NOTE**

**★ = Ask your HYOSUNG dealer or qualified machanic to do the maintenance items marked.**

## SEAT REMOVAL

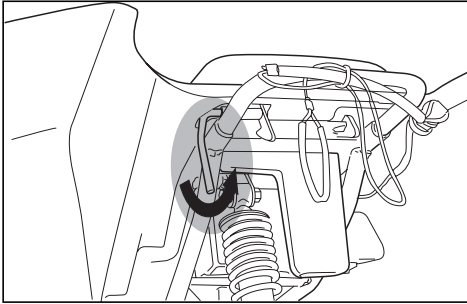

To remove the seat, pull the metal bar under the rear end of the seat and lift it up.

## TOOLS

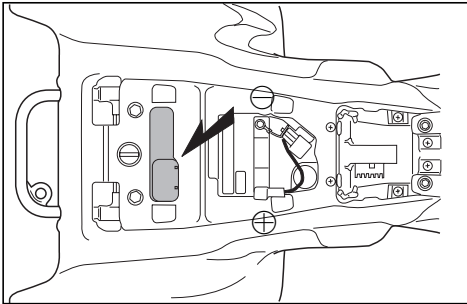

A tool kit is provided under the seat.

## AIR CLEANER

If the air cleaner element is clogged with dust, there will be greater intake resistance, resulting in decreased power output and increased fuel consumption

### CAUTION

- **DO NOT** operate the engine without the air cleaner element in place or severe engine damage may result.
- If you usually ride in dusty areas or regularly operate the vehicle in wet, muddy conditions, you must inspect the air cleaner element more frequently than shown in the periodic maintenance chart.
- If, at any time, the air cleaner element is submerged in water, immediately clean the element and the inside of the air cleaner case.

## ◉ Removing The Element

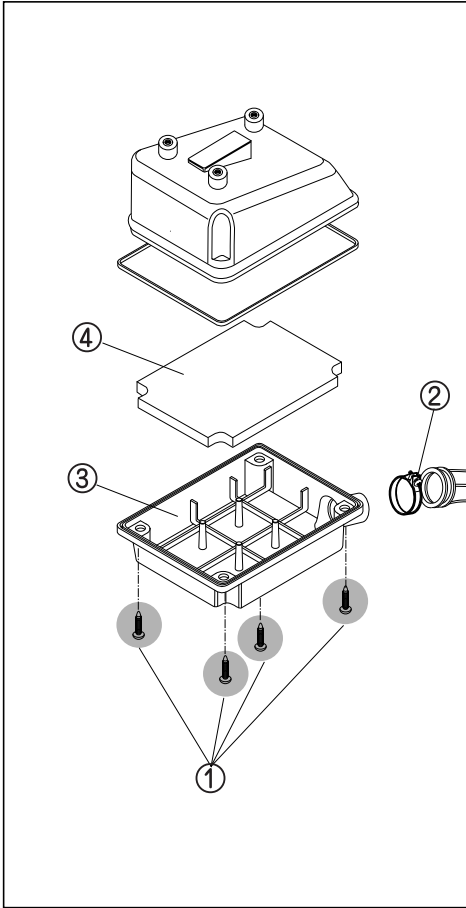

1. Remove the four bolts ①.
2. Remove the clamp screw ②.
3. Take out the air cleaner cap ③ and air cleaner element ④.

## ◉ Washing The Element

Wash the element as follows :

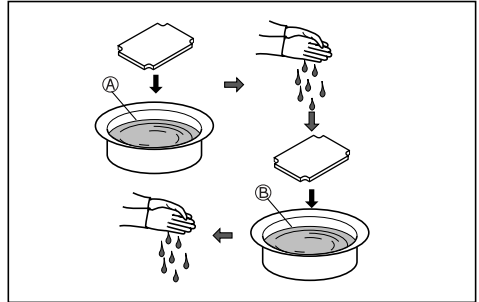

1. Fill a washing pan large enough to hold the element with a non-flammable cleaning solvent ①. Immerse the element in the solvent and wash it.
2. Squeeze the element by pressing it between the palms of both hands to remove excess solvent. Do not twist or wring the element or it will develop cracks.
3. Immerse the element in a separate pan filled with 2-stroke engine oil ②. Squeeze the element to remove excess oil. Make sure that the element remains damp with oil (but not soaked).

## **⚠ WARNING**

**Before, during, and after the cleaning operation, carefully examine the element for any tears in the material. A torn element could permit dirt and dust to pass into the engine. If the air cleaner element is torn, it must be replaced with a new one.**

4. Reinstall the cleaned element in reverse order of removal. Be sure that the element is securely in position and is sealing properly.



**WARNING**

**Keep cleaning solvent and oil away from children and pets. Dispose of used solvent and oil properly.**



**CAUTION**

**Be sure to position the air cleaner element correctly. Make sure it fits properly so that no incoming air will bypass it. Remember, rapid wear of piston rings and cylinder walls is often caused by an improperly positioned air cleaner element.**

**SPARK PLUGS**

Your **ATV** comes equipped with an BPR 6H S spark plug. You can determine if the standard spark plug is suitable for your type of vehicle usage by observing the color of the plug's porcelain center electrode insulator after vehicle operation. If the plug has the correct heat range, it should be very light brown in color. If the plug tends to run cold, (usually evidenced by blackening of the insulator or a wet electrode) replace it with an alternate plug according to the following chart.



**CAUTION**

**An improper spark plug may have an incorrect fit or heat range for your engine. This may cause severe engine damage which may not be covered under warranty. Use one of the spark plugs listed below or equivalents. Consult your HYOSUNG dealer if you are not sure which spark plug is correct for your type of vehicle usage.**

**PLUG REPLACEMENT GUIDE**

Hotter type	BPR5HS
Standard type	BPR6HS
Colder type	BPR7HS

If the above-named plugs are not available, consult your HYOSUNG dealer.



## CAUTION

To install a spark plug, turn it in as far as possible with your fingers, then tighten it with a wrench. Do not overtighten or cross thread the spark plug, or the aluminum threads of the cylinder head will be damaged. Do not allow contaminants to enter the engine through the spark plug hole when the plug is removed.

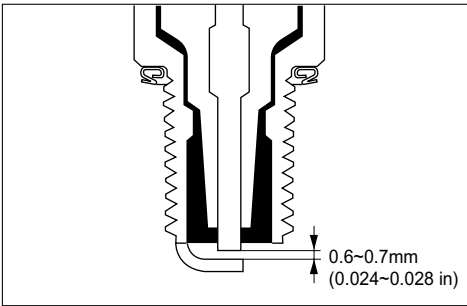
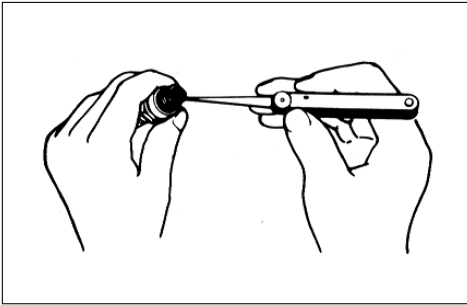

To maintain a hot, strong spark, keep the plug free of carbon. Remove carbon from the plug with a wire or pin, and adjust the gap to 0.6~0.7mm (0.024~0.028 in) for good ignition. Use a thickness gauge to check the gap.

## IDLE SPEED ADJUSTMENT

To adjust the idle speed properly, you need a engine tachometer. If you do not have one, ask your HYOSUNG dealer to perform this adjustment.

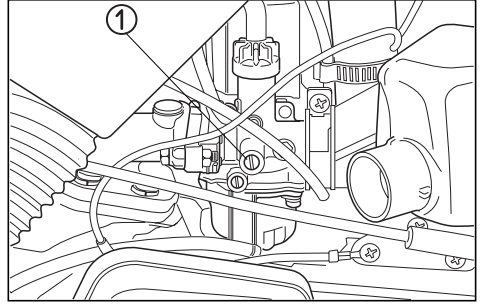

To adjust the idle speed :

1. Start the engine and warm it up.
2. After engine warms up, turn the throttle stop screw ① in or out so that the engine idles at lowest steady speed.



## CAUTION

**Make sure that the engine is fully warmed up before adjusting the engine idle speed. Improper adjustment can result in increased engine wear.**

## THROTTLE CABLE ADJUSTMENT

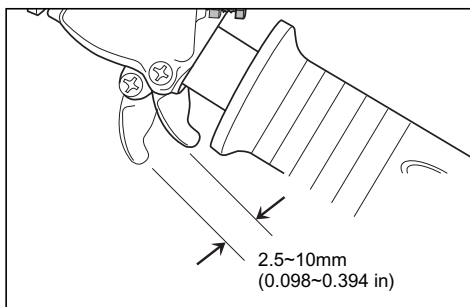

Measure the throttle cable play by pressing the throttle lever. The throttle lever should have 2.5~10mm (0.098~0.394 in) play.

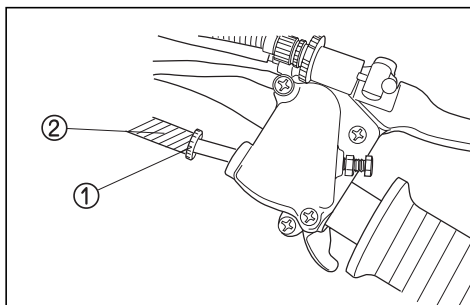

To adjust the throttle cable play:

1. Remove the adjuster cover.
2. Loosen the lock nut ①.
3. Turn the adjuster ② in or out to obtain the correct play.
4. Tighten the lock nut ①.
5. Recheck the throttle cable play. Readjust it if it is not within the correct limits.

## FUEL HOSE

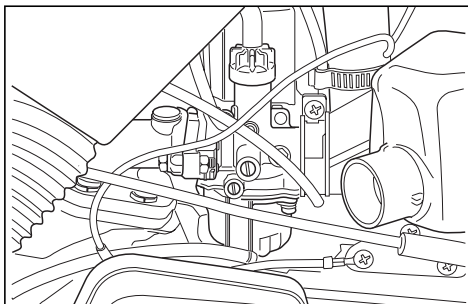

Replace the fuel hose every 4 years, even if it appears to be in good condition. Damage from aging may not always be visible.

## TRANSMISSION OIL

The transmission oil should always be changed when the engine is hot so that the oil's viscosity will be low and the oil will drain completely from the engine.

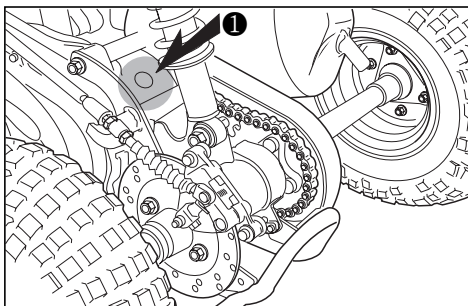

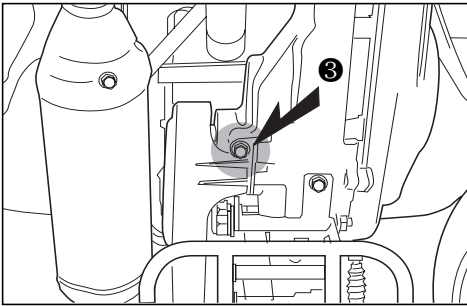
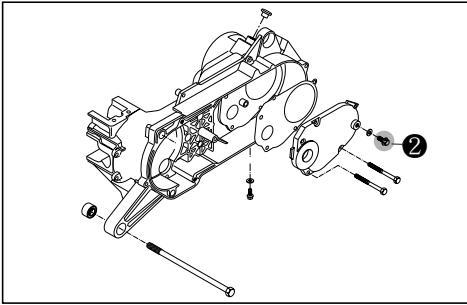

To change the oil :

1. Place the vehicle on level ground.
2. Remove the oil filler cap ①.
3. Remove the oil drain plug ③ from the bottom of the engine and drain the oil completely.
4. Reinstall the drain plug ③.
5. Remove the clutch cover.
6. Remove the level screw ② and pour fresh oil of the specified type through the filler hole until the oil flows out from the oil level hole.

TRANSMISSION OIL CAPACITY	
Replace	80 ml
Overhaul	90 ml

7. Refit the oil filler cap ① and oil level screw ②.

## CAUTION

**Frequent use in wet conditions will require more frequent oil changes. If the vehicle becomes submerged in water, immediately change the oil. Failure to follow these instruction may result in severe transmission damage.**

## ENGINE OIL LEVEL

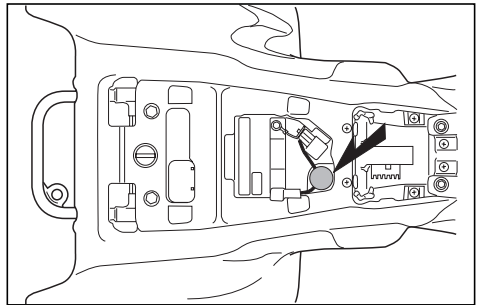

The engine oil tank is located under the seat. Check the oil level each time before starting the engine. If the oil level is low, fill up the tank with the specified oil. The oil tank holds 1.0 l

## WARNING

**Never operate the 「ATV」 without an adequate amount of oil, if the engine runs out of oil, it can stop suddenly, causing injury and/or severe mechanical damage.**

## BRAKE

The **ATV** has front drum brake and rear disk brake.

### WARNING

Failure to properly inspect and maintain your ATV's brake systems can be hazardous.

Improper maintenance of the brakes increases your chances of having an accident.

Be sure to inspect the brakes before each use of the vehicle according to the **INSPECTION BEFORE RIDING** section. Always maintain your brakes according to the **MAINTENANCE SCHEDULE**.

### WARNING

Operating the ATV in harsh condition can be hazardous if you do not inspect brake wear often.

Operating in mud, water, sand, or other extreme conditions can cause accelerated brake wear. This could lead to an accident.

If you operate your vehicle under these conditions, the brakes must be inspected more often than recommended in the **MAINTENANCE SCHEDULE**.

### ○ Front Brake

### ● Brake adjustment

### WARNING

Too much play in the front brake lever can cause poor braking performance and may lead to an accident.

Too little play may force brake shoes to rub against the drum at all times, causing damage to the shoes and the drum.

Follow the steps in this section to adjust the front brake lever properly.

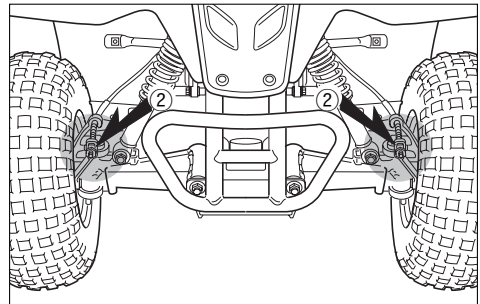
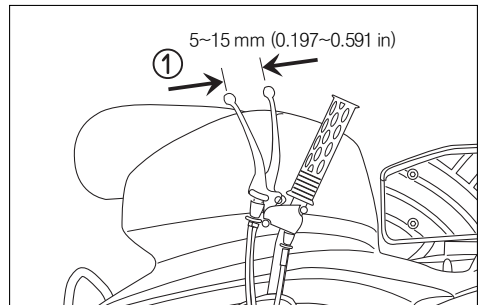

Adjust the free play ① to 5~15 mm (0.197~0.591 in) by screwing in or out the front brake adjusting nut ②.



### ● Brake lining wear limit

This vehicle is equipped with the brake lining wear limit indicators on the front brakes.

To check wear of the brake lining, perform the following :

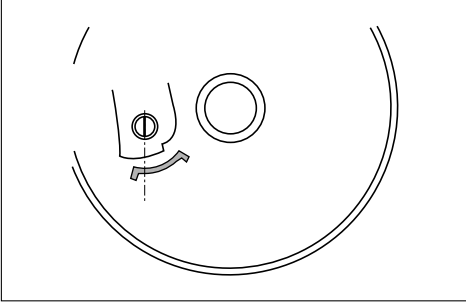

- ① Check if the brake system is properly adjusted.
- ② While fully applying the brake, check to see that the extension line of the index mark is within the range on the brake panel.
- ③ If the extension line is beyond the range, have the brake shoe assembly replaced by your Hyosung dealer to ensure safe operation.



## WARNING

**Riding with worn brake shoe will reduce braking performance and will increase your chance of having an accident.**

**Inspect brake shoe wear before each use. Ask your Hyosung dealer or qualified mechanic to replace brake shoe if the shoes are worn to the limit.**

### ○ Rear Brake

#### ● Brake adjustment

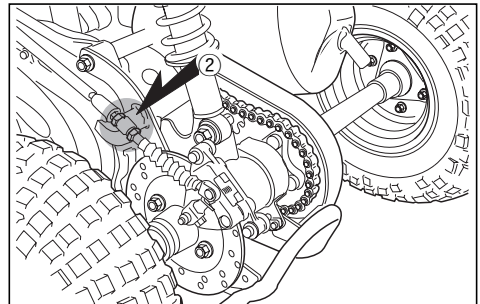
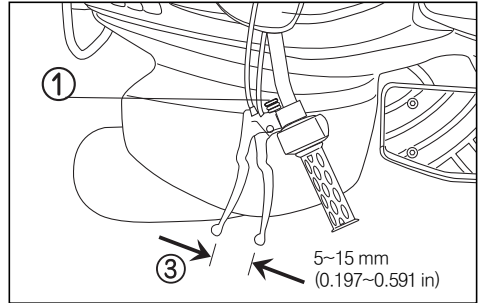

1. Set the parking brake by squeezing the rear brake lever and pressing the lock knob ①.
2. Try to move the vehicle backward and forward to see if the rear wheels are securely locked. If the rear wheels can turn, adjust the rear brake to lock the wheels securely by releasing the parking brake and turning the adjuster ② in. Repeat this procedure until the parking brake is properly adjusted.
3. Measure the amount of free play needed to lock the rear brake lever, as shown in the above illustration. Adjust the rear brake, if necessary, so that amount of free play ③ is about 5-15 mm (0.197-0.591 in) .
4. After any adjustment of the rear brake, check again to make sure the rear wheels can not turn when the parking brake lock knob is engaged.

● **Brake pads**

Inspect the rear brake pads by noting whether or not the friction pads are worn down to the grooved limit line. If a pad is worn to the grooved limit line it must be replaced with a new one by your authorized Hyosung dealer or qualified service mechanic.

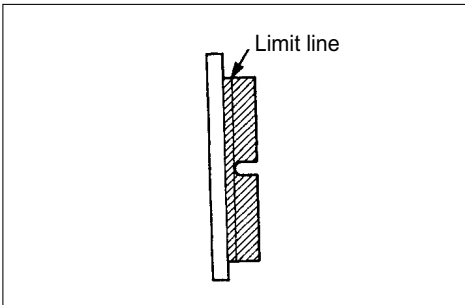
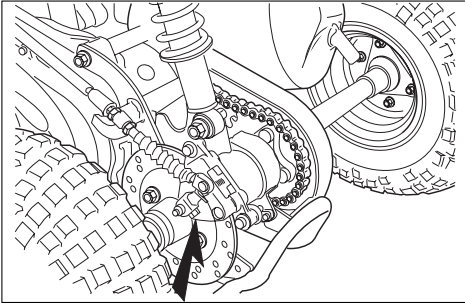

Inspect every day in the following point at the brake system.

- ① Operating of the brake lever.
- ② Wear of the rear brake pads.

**! WARNING**

**Riding with worn brake pads will reduce braking performance and will increase your chance of having accident. Inspect brake pad wear before each use. Ask your Hyosung dealer or qualified mechanic to replace brake pads if any pad is worn to the limit.**

**TIRES**

The **「ATV」** is equipped with low pressure tube tires of the size and type listed below :

	Front	Rear
Size & Type	145/70 - 6 SHIN-HUNG GOLDEN BOY	145/70 - 6 SHIN-HUNG GOLDEN BOY

**! WARNING**

**Using tires of a different size or type than the tires originally equipped on your ATV can change the ATV's handling characteristics. Different handling characteristics can result from differences in carcass construction, sidewall strength, tread pattern, etc.**

**! WARNING**

**For the rider's safety, check your vehicle's tires before each use of the vehicle, to make sure they have proper pressure, enough tread depth, and no damage.**

⦿ **Tire Tread Condition**

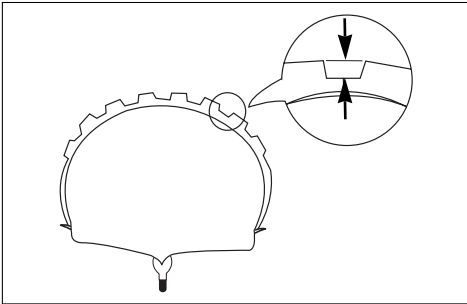

**⚠ WARNING**

**Operating the vehicle with excessively worn tires can cause skidding due to decreased traction. It is recommended that the front and rear tires be replaced when the depth of the tire tread is 4 mm (0.16 in) or less.**

⦿ **Tire Pressure**

A low pressure gauge is provided in tool kit under the seat, so you can measure the air pressure in your **「ATV」** tires. Check the air pressure in all tires before each use of the vehicle. Improper air pressure can affect handling, maneuverability, traction, tire life and rider comfort. Be sure that the tires are inflated to the pressures shown below. Tire pressure should only be measured or adjusted when the tires are cold, or misleading measurements can result.

COLD TIRE PRESSURE	
FRONT	25 KPa 0.25 kg/cm <sup>2</sup> 3.6 psi
REAR	25 KPa 0.25 kg/cm <sup>2</sup> 3.6 psi

**⚠ CAUTION**

**Using a high pressure air pump to fill the tires can be hazardous. If too much air is put into a tire, the tire may burst, causing severe injury. Use a manual type air pump to fill the tires.**

⦿ **Tire Replacement**

Air in the low-pressure tube tire of this vehicle is sealed by the contact surfaces of the inner wheel rim and the tire bead. If either the inner wheel rim or tire bead is damaged, air may leak. Be extremely careful not to damage these sections when replacing tires.

When breaking the tire bead loose from the wheel, be extremely careful not to damage the inner wheel surface or the tire bead.

It is very important to use the proper tools when repairing or replacing tires, to prevent damage to the tire bead or wheel rims. We highly recommend that you have such work done by your HYOSUNG dealer or a qualified tire repair station.

⦿ **Tube Tire Repair**

Should a leak or flat tire occur due to a puncture, the tire may be repaired using a plug type patch. If the damage is from a cut, or if the puncture cannot be repaired using a plug, the tire should be replaced. When operating your **「ATV」** in areas where transportation or service facilities are not readily available, it is strongly recommended that you bring a plug type repair kit and a tire pump with you.

## DRIVE CHAIN

The chain may require more frequent adjustment than it is with periodic maintenance depending upon your riding conditions. Inspect and lubricate every month. If it becomes necessary to replace the drive chain, we recommend that you take your vehicle to an authorized HYOSUNG dealer to have the work done.

You should periodically inspect the drive chain for the following :

- Loose pins
- Damaged rollers
- Dry or rusted links
- Kinked or binding links
- Excessive wear

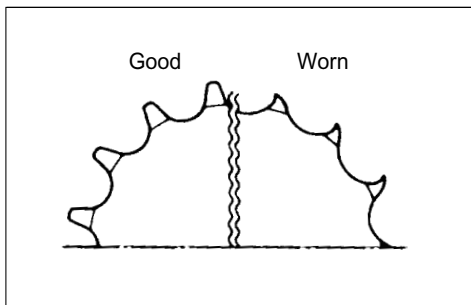

If you find anything wrong with the drive chain condition or adjustment, there is a strong possibility that the sprockets will have some damage to them also. Inspect the sprockets for the following:

- Excessively worn teeth
- Broken or damaged teeth
- Loose sprocket mounting nut(s)

### ◉ Drive Chain Cleaning and Oiling

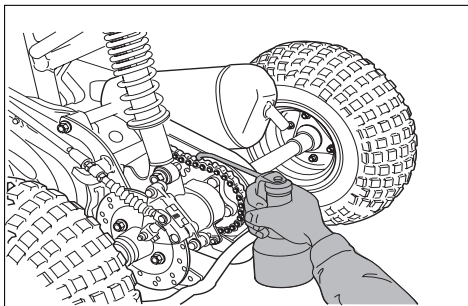

Clean and oil the chain as follows :

1. Wash the chain with kerosene. Kerosene is a petroleum product and will provide some lubrication as well as cleaning action.

#### **⚠ WARNING**

**Keep kerosene away from children and pets. Dispose of used kerosene properly.**

#### **⚠ CAUTION**

**Do not use gasoline or other commercial cleaning solvents to clean the drive chain.**

2. After thoroughly washing the chain and allowing it to dry, oil the links with a heavy weight motor oil.

### ◉ Inspect Drive Chain Slack

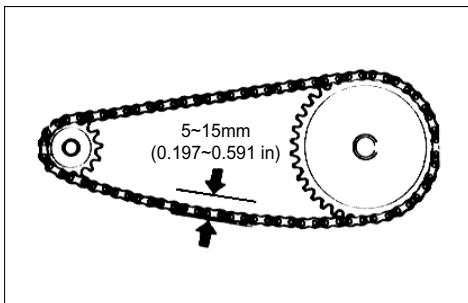

The slack in the drive chain to 5~15mm (0.197~0.591 in).

If exceed 15mm (0.591 in) of the drive chain slack, replace the drive chain with a new one.

## WARNING

**Failure to inspect the drive chain slack before each use of the vehicle could be hazardous. Too much chain slack could cause the chain to come off the sprockets, resulting in an accident or serious damage to the vehicle.**

**Inspect the drive chain slack before each use.**

## FOOTREST HEIGHT ADJUSTMENT

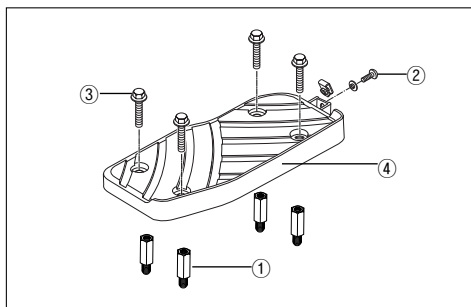

This vehicle is equipped with a footrest lower bolts ①.

To adjust height of the footrest, perform the following :

1. Remove the footrest screws ②.
2. Remove the footrest bolts ③.
3. Remove the footrests ④, right and left.
4. Install the footrest lower bolts ①.
5. Install the footrests ④, right and left.
6. Tighten the footrest bolts ③.
7. Tighten the footrest screws ②.

## FRONT AND REAR WHEEL REMOVAL

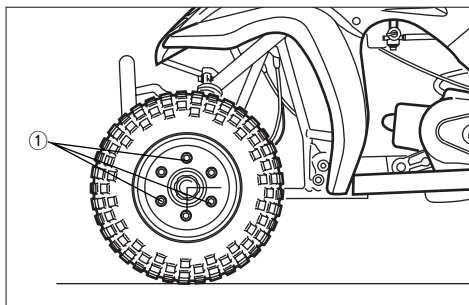

1. Place the vehicle on level ground and set the parking brake.
2. Loosen the three wheel nuts ① on the wheel to be removed.
3. Lift up the front or rear end of the vehicle by placing a jack or block under the axle or frame.
4. Remove the three wheel nuts.
5. Remove the wheel. To reinstall the wheel, reverse these steps.

## WARNING

**When replacing a wheel, it is very important that the wheel axle nuts be torqued to the proper specifications. If they are not, the wheel can come off unexpectedly. We strongly recommend that you have these nuts checked and retorqued, if necessary, by your authorized HYOSUNG dealer.**

### Tighten Tirque

Front and Rear wheel nut	25 N · m (2.5kg · m)
--------------------------	-------------------------

## GENERAL LUBRICATION

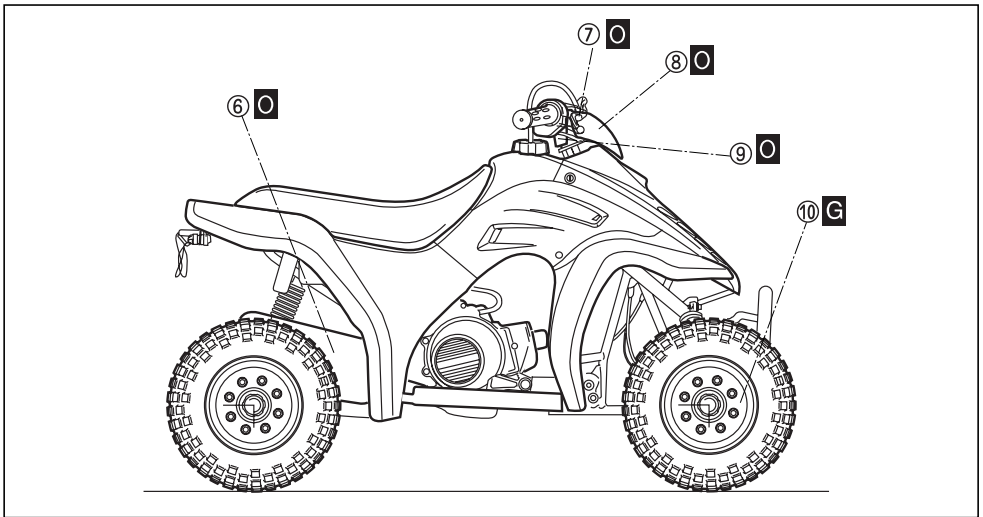
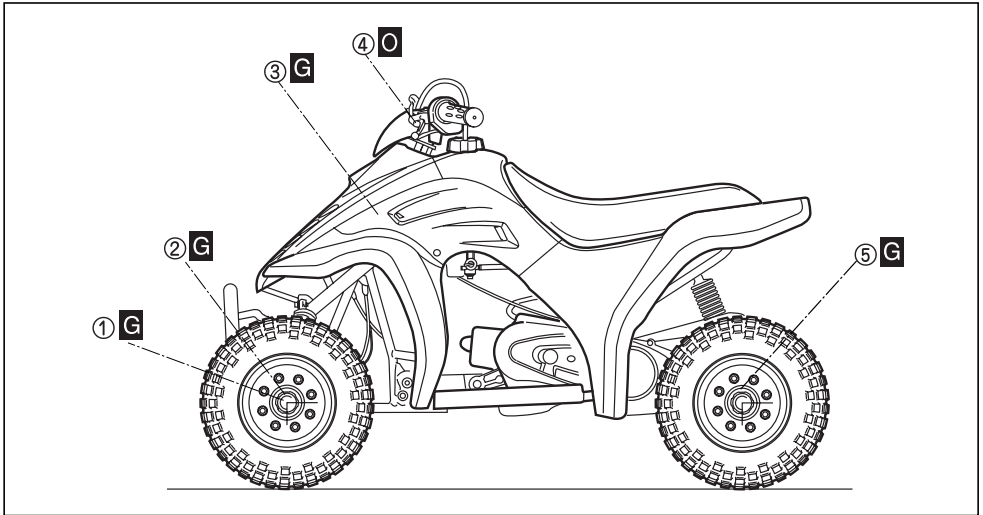

- |                         |                         |
|-------------------------|-------------------------|
| ① King pin              | ⑥ Drive chain           |
| ② Front wheel bearing   | ⑦ Front brake cable     |
| ③ Steering shaft holder | ⑧ Throttle cable        |
| ④ Rear brake cable      | ⑨ Throttle lever        |
| ⑤ Rear axle housing     | ⑩ Front brake cam shaft |

**O** ..... Motor oil  
**G** ..... Grease

Proper lubrication is important for safe, smooth operation and long life of each working part of your vehicle. Pay attention to the need for lubrication when you perform periodic maintenance on the vehicle. Be sure to have your authorized HYOSUNG dealer perform a general lubrication as shown in the maintenance chart on page 25. Your authorized HYOSUNG dealer will lubricate such items as wheel bearings, rear axle housings, steering shaft holder, etc.

---

## TROUBLE SHOOTING

---

### CAUTION

**It is best to consult your HYOSUNG dealer before attempting to troubleshoot any problem. Damage may result from inappropriate repairs or adjustments. Such damage may not be covered under warranty.**

This troubleshooting guide is provided to help you identify the cause of some common complaints.

★ **COMPLAINT :** Engine is hard to start or does not start at all.

Something is probably wrong with the fuel system or ignition system.

### ■ FUEL SYSTEM CHECK

1. Make sure there is adequate fuel in the fuel tank.
2. Check that the engine stop switch is in the  position.
3. Check that the remote engine stop switch cap is installed on the remote engine stop switch.
4. Make sure there is enough fuel reaching the carburetor from the fuel tank.
  - a. Loosen the drain screw which is located under the carburetor and drain the fuel from the carburetor.

### WARNING

**Do not allow the fuel to spill; catch the fuel in a container. Do not allow any fuel to come in contact with the hot engine or exhaust system. Extinguish any smoking materials before performing this check, and stay away from any open flames or heat sources.**

- b. Tighten the drain screw.
- c. Remove the spark plug.
- d. Loosen the drain screw and check that the carburetor is filled back up with fuel.
- e. If it has been determined that fuel is reaching the carburetor, the ignition system should be checked next.

## ■ IGNITION SYSTEM CHECK

### ★ COMPLAINT : Engine stalls

1. Make sure there is enough fuel in the fuel tank.
  2. Check to see that the spark plug is not fouled.  
Remove the plug and decarbon or replace it, if necessary.
  3. Make sure the fuel cock is clear. Also check connected to the fuel tank cap is not clogged.
- 
1. Remove the spark plug and reattach it to the spark plug lead.
  2. While holding the spark plug firmly against the engine, push the starter switch with the engine stop switch in the ○ position and the remote engine stop switch cap is installed on the remote engine stop switch. If the ignition system is operating properly, a blue spark should jump across the spark plug gap. If there is no spark, take your machine to you authorized HYOSUNG dealer.



## WARNING

**Do not check for a spark unless you are certain that you know how to do it; you could get a high voltage electrical shock. When testing for a spark, do not point the spark plug near the spark plug hole. There may be some fuel inside the cylinder which could be ignited. Due to the possibility of electrical shock, anyone with a heart condition or pacemaker should avoid this check.**

## TRANSPORTING

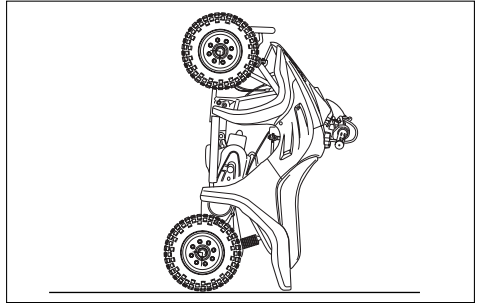
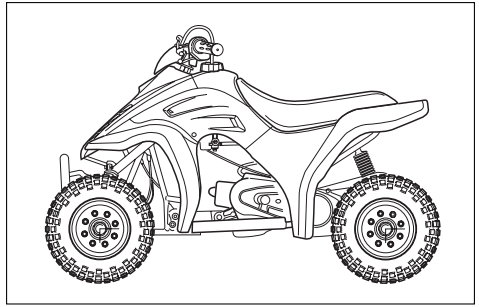

The **「ATV」** should be transported in the normal position, if possible. It may also be transported in the standing position, but the standing position is not as stable as the normal position.

Before transporting the **「ATV」**, drain the fuel from the carburetor as follows :

1. Turn the fuel cock lever to the OFF position.
2. Drain fuel from the carburetor into a suitable container by loosening the carburetor drain bolt.
3. When the fuel has drained completely, retighten the drain bolt.





## WARNING

**When draining the carburetor, always shut the engine off. Do not smoke, and never drain or refuel in an area where there are open flames or sparks.**



## WARNING

**Be sure to use a suitable container to catch the fuel you drain from the carburetor. Do not allow the fuel to spill or you may create a fire hazard. Keep fuel out of the reach of children and pets or they may be injured, and dispose of unwanted fuel properly.**



## WARNING

**When transporting the 'ATV', lock the parking brake and tie down the vehicle securely with rope or some other suitable means. Use extra tie downs when you transport the vehicle in the standing position. Failure to properly secure the vehicle may result in an accident or damage to the vehicle.**

### ★ STARTING THE 'ATV' AFTER TRANSPORT

To feed fuel into the carburetor, turn the fuel cock to the ON position.

## CLEANING PROCEDURE

A thorough cleaning of your ATV is a necessary part of maintenance and will help keep your ATV looking and performing its best. Proper cleaning can also extend the life of your ATV.

It is important to clean and inspect your ATV after every ride if it is used in mud, brush, grass, water, salt water, or very dusty conditions.

The build-up of mud, brush, grass, etc, especially on the engine and exhaust system, can reduce engine cooling, conceal damage, or increase wear of certain parts. It is important to remove all debris during cleaning.

### ★ PREPARATION FOR CLEANING

Wash the ATV before any mud dries on the ATV.

Block or seal the end of the exhaust pipe (muffler) using a piece of plastic wrap, cloth rag or another method to prevent water from entering the engine.



## CAUTION

**High pressure washers can damage your ATV.**

**High pressure washers such as those found at coin-operated car washes have enough pressure to damage the parts of your ATV. It may cause rust, corrosion and increase wear.**

**Do not use high pressure washers to clean your ATV.**

### ★ WASHING YOUR ATV

With some care, your ATV can be washed in a similar manner to washing an automobile.

**NOTE : Avoid spraying or allowing water to flow over the following places :**

- Spark plug
- Fuel tank cap
- Carburetor

Use a garden hose at low pressure to remove the majority of dirt or other debris. Hand wash your ATV with a mild soap or detergent and water. Try to thoroughly remove all dirt and debris without excessive water pressure. Cloth rags, washing mitts or cleaning brushes can be used, be careful with brushes as they may scratch plastic or painted surfaces. Rinse the ATV thoroughly with clean water. Dry all areas using a chamois or soft absorbent cloth.

### ★ INSPECTION AFTER CLEANING

Remove the rags or wrapping from the exhaust pipe. For extended life of your ATV, lubricate according to GENERAL LUBRICATION section.



## WARNING

**Operating ATV with wet brakes can be hazardous.**

**Wet brakes may not provide as much stopping power as dry brakes. This could lead to an accident.**

**Test your brakes after washing ATV, while riding at slow speed. If necessary, apply brakes several times to let friction dry out the linings and pads.**

Follow the procedures in the INSPECTION BEFORE RIDING section to check your ATV for any problems that may have arisen during your last ride.

## STORAGE PROCEDURE

If your **「ATV」** is to be left unused for an extended period of time, it needs special servicing requiring appropriate materials, equipment and skill. For this reason, HYOSUNG recommends that you trust this maintenance work to your HYOSUNG dealer. If you wish to service the machine for storage yourself, follow the general guidelines below:

### ★ VEHICLE

Place the vehicle on level ground and thoroughly clean the entire vehicle.

### ★ FUEL

Drain the fuel from the fuel tank using a commercially available hand pump or siphon. Drain the fuel from the carburetor using the carburetor drain screw.



### WARNING

**Do not allow the fuel to spill; catch the fuel in a suitable container. Do not allow any fuel to come in contact with the hot engine or exhaust system. Extinguish smoking materials before draining any fuel and stay away from any other fire or heat source. Keep pets and children away from fuel, and dispose of unwanted fuel properly.**

### ★ ENGINE

Pour one tablespoon of motor oil into the spark plug hole. Reinstall the spark plug and crank the engine a few times.

### ★ TIRES

Inflate tires to the normal specifications.

### ★ EXTERNAL

- Spray all vinyl and rubber parts with rubber preservative.
- Spray unpainted surfaces with rust preventative.
- Coat painted surfaces with car wax.

### ★ PROCEDURE FOR RETURNING TO SERVICE

- Clean the entire vehicle.
- Reinstall the battery.



### CAUTION

**Make sure that the battery lead wire is routed properly.**

- Remove the spark plug. Turn the engine a few times by pushing the starter switch. Reinstall the spark plug.
- Make sure that the vehicle is properly lubricated.
- Perform the INSPECTION BEFORE RIDING as listed in this manual.

## LOCATION OF LABELS

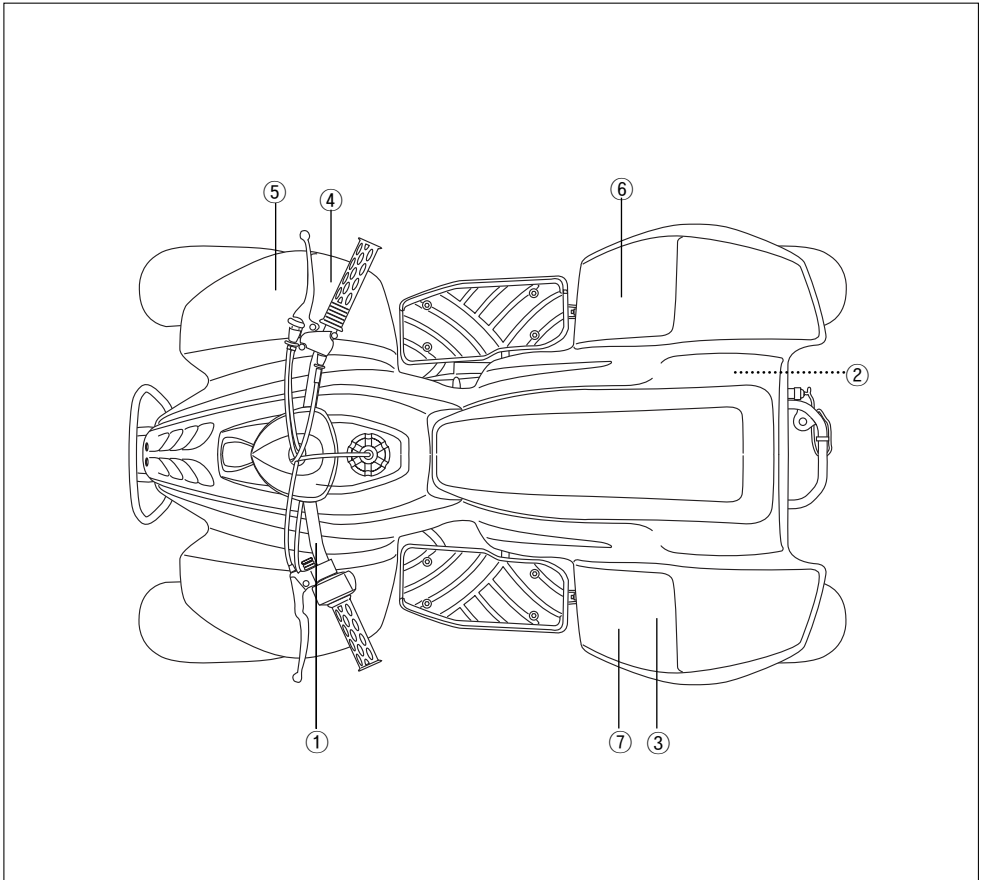

1

**SET PARKING BRAKE BEFORE STARTING ENGINE.**  
68343 H K3100

2

**⚠ WARNING**  
**DO NOT TOUCH MUFFLER WHEN ENGINE IS IN OPERATION.**  
68320 H K3100

3

**⚠ WARNING**

Operation of this ATV by children under the age of **6** increases the risk of severe injury or death. Adult supervision required for children under age **12**. **NEVER** permit children under age **6** to operate this ATV.

68931 H K3100

6

**⚠ WARNING**

Improper tire pressure or overloading can cause loss of control. Loss of control can result in severe injury or death.

**ALWAYS** maintain proper tire pressure as shown below.

**NEVER** exceed the Vehicle Load Capacity of **77 lbs (35kg)**.

LOAD	COLD TIRE PRESSURE
UP TO 77 lbs 35 kg	FRONT 3.6 psi (0.25 kgf/cm <sup>2</sup> ) REAR 3.6 psi (0.25 kgf/cm <sup>2</sup> )

TIRE SIZE: FRONT 145/70-6  
REAR 145/70-6

68332 H K3100

4

**⚠ WARNING**

Improper ATV use can result in SEVERE INJURY or DEATH



ALWAYS USE AN APPROVED HELMET AND PROTECTIVE GEAR



NEVER USE ON PUBLIC ROADS



NEVER CARRY PASSENGERS

**NEVER** operate:

- without proper training or instruction
- at speeds too fast for your skills or the conditions
- on public roads – a collision can occur with another vehicle
- with a passenger – passengers affect balance and steering and increase risk of losing control

**ALWAYS:**

- use proper riding techniques to avoid vehicle overturns on hills and rough terrain and in turns
- avoid paved surfaces – pavement may seriously affect handling and control

**LOCATE AND READ OWNER'S MANUAL. FOLLOW ALL INSTRUCTIONS AND WARNINGS.**

68921 H K3100

**⚠ WARNING**



**NEVER** ride as a passenger.

Passengers can cause a loss of control, resulting in SEVERE INJURY or DEATH.

68367 H K3100

5

7

**⚠ WARNING**

FAILURE TO TAKE THE FOLLOWING SAFETY PRECAUTIONS CAN RESULT IN SERIOUS PERSONAL INJURY.

- READ OWNER'S MANUAL CAREFULLY BEFORE OPERATION TO FAMILIARIZE YOURSELF WITH THIS VEHICLE'S UNIQUE HANDLING CHARACTERISTICS, PROPER RIDING TECHNIQUES, AND DETAILED SAFETY PRECAUTIONS. INSTRUCT ALL RIDERS ACCORDINGLY. THE OWNER'S MANUAL IS PROVIDED IN THE PACKING OF THIS VEHICLE.
- MAKE SURE ALL RIDERS UNDERSTAND THAT EVEN THOUGH THIS VEHICLE HAS FOUR WHEELS, IT CAN TIP OVER IN ANY DIRECTION IF IT IS IMPROPERLY USED.
- NO RIDERS UNDER AGE 6.
- ADULT MUST SUPERVISE OPERATION AT ALL TIMES.
- USE ONLY OFF - ROAD. NEVER USE ON PUBLIC ROADS OR PAVEMENT.
- SINGLE RIDER ONLY - NO PASSENGERS.
- WEAR HELMET, EYE PROTECTION AND PROTECTIVE CLOTHING.
- ADULT MUST PERFORM DAILY INSPECTION BEFORE OPERATION.
- TIRE INFLATION PRESSURE AND TIRE CHARACTERISTICS CAN AFFECT VEHICLE HANDLING. SEE THE TIRE INFORMATION LABEL AND YOUR OWNER'S MANUAL. A TIRE PRESSURE GAUGE IS IN THE TOOL KIT UNDER THE SEAT.
- ENGINE STARTING AND REFUELING MUST BE DONE BY ADULTS ONLY.
- WHEN REFUELING, DO NOT SMOKE, AND AVOID SOURCES OF SPARK OR FLAME.
- USE THE REMOTE ENGINE STOP SWITCH CAP AS A KEY TO PREVENT UNAUTHORIZED USE.
- DO NOT ALLOW THIS VEHICLE TO BE RIDDEN AT NIGHT.
- DO NOT EXCEED VEHICLE LOAD CAPACITY SHOWN ON THE TIRE INFORMATION LABEL.
- WHEN USING ACCESSORIES OR CARRYING LOADS, FOLLOW THE GUIDELINES IN THE OWNER'S MANUAL.

RIDE SAFELY, PRESERVE NATURE, AND BE THOUGHTFUL OF OTHERS

68366 H K3100

---

# SPECIFICATIONS

---

## DIMENSIONS AND DRY MASS

Overall length .....	1,250 mm (49.2 in)
Overall width .....	780 mm (30.7 in)
Overall height .....	825 mm (32.5 in)
Wheelbase .....	915 mm (36.0 in)
Ground clearance .....	80 mm (3.2 in)
Front track .....	630 mm (24.8 in)
Rear track .....	630 mm (24.8 in)
Mass .....	85 kg (187.5 lbs)

## ENGINE

Type .....	Two-stroke, forced air-cooled
Intake system .....	Reed valve
Number of cylinder .....	1
Bore x Stroke .....	41.0 × 37.4 mm (1.61 × 1.47 in)
Piston displacement .....	49 cm <sup>3</sup> (3.9 cu.in)
Corrected compression ratio .....	7.4 : 1
Carburetor .....	VM14SH
Air cleaner .....	Polyurethane foam element

## TRANSMISSION

Reduction ratio .....	2.818~0.870
2nd reduction ratio .....	12.0
Final reduction ratio .....	1.333
Drive chain .....	SLC 428H 50 links

## CHASSIS

Front brake .....	Drum
Rear brake .....	Disk
Front tire size .....	145/70-6
Rear tire size .....	145/70-6

## ELECTRICAL

Ignition type .....	HYOSUNG CDI
Spark plug .....	BPR6HS

## CAPACITIES

Fuel tank .....	4.0 ℓ
Engine oil tank .....	1.0 ℓ
Transmission oil .....	80 ml (Replace)
	90 ml (Overhaul)



Prepared by

**HYOSUNG MOTORS & MACHINERY INC.**

Overseas Technical Dept

1st Ed. FEB. 2001.

Printed in KOREA